



MEETING AGENDA
for
PLANNING, RESOURCES AND OPERATIONS
COMMITTEE

October 25, 2022 @ 3 pm
by Virtual/Online or Teleconference

Please join our meeting from your computer, tablet or smartphone.

<https://meet.goto.com/412843565>

You can also dial in using your phone.

United States: [+1 \(224\) 501-3412](tel:+12245013412)

Access Code: 412-843-565

▪ **Call to Order**

1. Recognitions and Presentations:

2. Additions-Deletions to the Agenda:

3. Public Comments

This is the time for any shareholder or member of the public to address the committee members on any topic under the jurisdiction of the Company, which is on or not on the agenda. Please note, pursuant to the Brown Act the Committee is prohibited from taking actions on items not listed on the agenda. For any testimony, speakers are requested to keep their comments to no more than four (4) minutes, including the use of any visual aids, and to do so in a focused and orderly manner. Anyone wishing to speak is requested to voluntarily fill out and submit a speaker's form to the manager prior to speaking.

4. Approval of Committee Meeting Minutes

A. Regular Committee Minutes of June 28, 2022

5. Planning and Operational Issues:

6. Planning and Operational Updates:

A. Project Status Report/Project List

Report on on-going projects

B. Paloma Curve Hydraulic Break

Review and Discuss Technical Memorandum from WSC

C. Surface Water Treatment Plant

Review and Discuss Draft Budgetary Study from TKE for Possible Treatment Plant

7. Basin Issues and Updates:

- San Antonio Canyon Watershed – Verbal report
- Chino Basin - Verbal report
- Six Basins - Verbal report
- Cucamonga Basin – Verbal report

8. Closed Session: None.

9. Committee's Comments and Future Agenda Items:

This is the time for the Committee to comment and consider future agenda items relative to planning, water resources and operations of the company and its shareholders.

Adjournment:

The next regular PROC Meeting will be held on February 28, 2023 at 3:00 p.m.

NOTE: All agenda report items and back-up materials are available for review and/or acquisition at the Company Office (139 N. Euclid Avenue, Upland, CA.) during regular office hours, Monday through Thursday [8:00 – 11:30 & 12:30 – 4:00] and alternating Fridays [8:00 – 11:30 & 12:30 – 3:00]. The agenda is also available for review and copying at the City of Upland at 460 N. Euclid Avenue and Upland Public Library located at 450 N. Euclid Avenue.

POSTING STATEMENT: On October 20, 2022 a true and correct copy of this agenda was posted at the entry of the Company Office (139 No. Euclid Avenue), at the City of Upland at 460 N. Euclid Avenue, on the public bulletin board at 450 N. Euclid Avenue (Upland Public Library), and on the Company website.

MINUTES OF THE SAN ANTONIO WATER COMPANY
 PLANNING, RESOURCES, and OPERATIONS COMMITTEE
 June 28, 2022

An open meeting of the Planning, Resources, and Operations Committee (PROC) of the San Antonio Water Company (SAWCo) was called to order virtually at 3:00 p.m. on the above date. Committee members present were Will Elliott, Kati Parker, and Rudy Zuniga. Also in attendance were SAWCo's General Manager Brian Lee and Assistant General Manager Teri Layton. Director Elliott presided.

1. Recognitions and Presentations – None.
2. Additions-Deletions to the Agenda – None.
3. Public Comments – None.
4. Approval of Committee Meeting Minutes:
 - A. ***Regular Committee Minutes of April 26, 2022*** – Director Zuniga moved, and Director Parker seconded to approve the meeting minutes of April 26, 2022 as presented. Motion carried unanimously with Director Bowcock absent.
5. Planning and Operational Issues:
6. Planning and Operational Updates -
 - A. **Project Status Report/Project List** – Mr. Lee advised very little has changed since the report given at the Board meeting held the previous week. Staff is in discussions with the consultant for the 2020 Water Master Plan regarding discrepancies between the model and field conditions on pressure. The model shows higher pressure than what is being seen in the field. There is concern this indicates a valve, or something partially close, constricting the system. Finalizing the master plan is delayed for this reason.

Director Parker inquired as to the goal of the master plan. Mr. Lee answered the master plan is to assess the physical components of SAWCo's system and to build a shopping list of replacements for the system. This particular master plan has a sub interest looking at water dependability and source water reliability. The portions of the plan that Mr. Lee has reviewed are positive and the system is in good shape.

The contract for Well 19 was reviewed by Mr. Lee earlier in the day and he will be sending a signed copy to the contractor to allow for work to begin on the test well.

Director Bob Bowcock joined the meeting at 3:03 p.m.

The Booster 19 Holly Drive generator has been installed. The landscaping around the booster has not been installed as Mr. Lee has been unable to get ahold of the current owner of the property for approval to begin work. It is not advisable to

plant trees and the like during the summer heat which provides Mr. Lee additional time to get the approval from the property owner to begin work.

The draft technical memorandum for the installation of a treatment plant is expected shortly. It is expected to deal with the periods when system flows are below one million gallons per day which the City of Upland cannot currently treat with their treatment plant. After SAWCo executed the contract for their own treatment plant, the City of Upland began looking for funding opportunities through the state to add to their treatment plant allowing processing of lower flows. Mr. Lee is in contact with the public works director of Upland, Braden Yu, regarding these projects to see in the end which one makes better sense.

Director Elliott inquired about the New Office and Yard Relocation project. Mr. Lee advised he will be inquiring about the interest in the project to determine whether to move forward or remove it from the books.

- B. Glendale Drive Pipeline Replacement** – Mr. Lee stated he included the proposals for the project in the agenda packet for the Committee to review and respond with whom they felt to be the most responsive consultant. Consulting fees were not included in order to prevent being swayed by cost and rather focus on which one will provide the best service.

Director Elliott commented the Company has had good experiences with Civil Tech Engineering in the past.

Director Parker stated she is partial to Ardurra's proposal. She believed the proposal to be fairly complete and liked the fact that the project manager is local. Provost & Pritchard on the other hand works with a subconsultant for the engineering portion which she did not care for.

Mr. Lee commented the two firms, Ardurra and Civil Tech Engineering, are the firms he preferred out of the four that submitted proposals. The RFP was sent to a total of five firms, Mr. Lee has worked with all five firms in the past and is comfortable working with all of them. Ardurra took over IEC, IEC is the company Mr. Lee worked with in the past and the principal on the project is one he has worked with at IEC.

Mr. Lee then presented the proposed fees of each firm. He explained the design costs were very similar for three of the four firms. Construction costs varied a bit more. With Civil Tech Engineering recently completing a project for SAWCo, they are more aware of the actual construction needs where the other firms proposed fees for construction costs can be tightened up. SAWCo field staff actively monitors construction projects and therefore the need for construction services is probably quite a bit less than the firms have proposed. He is confident he can reduce the proposed construction fees of the other firms. With that being said, Mr. Lee stated he leaned towards Ardurra as the most responsible consultant.

The Committee continued to discuss the firms, their proposals, and costs.

Director Parker moved to recommend the Board approve, out of the four firms that submitted proposals, utilizing Ardurra for the Glendale Road Pipeline Project with the caveat that the General Manager negotiate the final costs. Director Zuniga seconded, and the motion carried unanimously.

7. Basin Issues and Updates

- Mr. Lee encouraged the Committee to read SAWCo's most recent newsletter; it is available on the Company's website. There is information about the drought and the Company's efforts to ramp up conservation efforts for shareholders utilizing Inland Empire Utilities Agency (IEUA) programs. Staff is not currently looking at reducing entitlement this year. Domestic customers should be able to utilize their full entitlement whereas staff is working with municipal customers to maximize the amount of water captured in the canyon to deliver nearly all, if not all, of their entitlement.

Director Parker complimented Mr. Lee on the newsletter. In particular, she enjoyed the cost per fluid comparison on the back page.

- ***San Antonio Canyon Watershed*** – No report given.
- ***Chino Basin*** – No report given.
- ***Six Basins*** – No report given.
- ***Cucamonga Basin*** – No report given.

8. Closed session: None.

9. Committee's Comments and Future Agenda Items: Director Bowcock commented that he has worked with several of the current Board members in the past and is looking forward to working with them again. He also stated he is excited to work for the first time with Director Zuniga and build a new relationship. He then thanked them all for this opportunity.

Adjournment: –The meeting adjourned at 3:28 p.m.

Assistant Secretary
Brian Lee

Agenda Item No. 6A

Item Title: Projects and Operations Update

Purpose:

To update the Board and Shareholders on Company capital projects.

Updates:

1507 – Office Relocation

~~Staff has discussed a possible solution with the City and is presenting a path forward at tonight's meeting.~~ The option under consideration is constructing an administrative and operations campus on Company property at 20th Street, without a Board Room. At it's September 2022 regular meeting the Board authorized staff to move ahead with a feasibility study of the 20th street property. Staff has contracted with CEDG, Inc. to complete said study, including ingress/egress and a conceptual site plan.

Original Budget.....	\$14,600
Original Contracts.....	\$14,600
Authorized Change Orders	NA
Current Contracts	\$14,600

1602 – Holly Drive Reservoir, Phase 3

Proposed construction of a second 120,000-gallon tank at the Holly Drive Tank site. Professional services agreement has been fully executed. ~~Predesign meeting being scheduled. Plans have been reviewed and comments returned to consultant. Final plans are being prepared and project will be bid next month.~~ Project is out to bid this month. Bid opening is scheduled for November 30th @ 2pm.

1902 – Cucamonga Crosswalls Mitigation

TKE Engineering is working with staff to close out certain State and Federal Permits. Staff is also looking into long-term maintenance permits that will allow the Company yearly access to the site for clearing and grubbing.

1905 – 2020 Master Plan

~~Staff is presenting a \$20,000 change order at tonight's meeting to focus on improved accuracy of the computer model as discussed below. Board authorized a change order at the regular September 2022 meeting to address computer model issues discussed below.~~ Computer Water Model being constructed by consultant. Staff is coordinating with consultant regarding areas of concern in the water model to improve accuracy. Revised schedule is to complete Master Plan by end of October summer. There remains a gap between field pressures and hydraulic model pressures indicating a restriction in our system. Staff and consultant are investigating. It may be a partially closed valve. Staff has asked consultant to separate hydraulic modeling issues from remainder of Master Plan and complete the Plan. ~~Hydraulic modeling issues will be moved to a separate project.~~ Staff is currently reviewing draft chapters and hydraulic profiles. Confirming system pressures in the field with computer simulation model pressures.

Original Budget.....	\$240,000
Original Contracts.....	\$204,085
Authorized Change Orders	\$20,000

Current Contracts\$224,085

2007 Well 19

Project approved at April 2022 Board Meeting. Contract has been completed. Material being ordered and we are currently scheduling the start of work. Staff was informed this month that material deliveries (specifically the fiberglass casing) is delayed until early 2023. Test will has been delayed until start of next year.

Original Budget..... \$1,130,990
Original Contracts \$1,130,990
Authorized Change Orders NA
Current Contracts \$1,130,990

2112 Treatment Plant

Technical memorandum discussing the pros and cons of a company treatment plant. Contract with TKE fully executed. Scheduling pre-design meeting. Pre-design meeting held and data review is ongoing. Consultant conducted a site visit in late February. Draft technical report has been received by the Company and will be discussed at next week's PROC meeting. ~~due this week.~~

Original Budget\$27,000
Original Contracts\$24,500
Authorized Change Orders..... NA
Current Contracts \$24,500

2201 Paloma Hydraulic Break

Technical study to review available options to modernize the facility and reduce low frequency noise during high waterflow events. Contract has been fully executed. Predesign meeting held. Options discussed. ~~Consultant working on tech memo.~~ Draft technical report has been received by the Company and will be discussed at next week's PROC meeting.

Original Budget\$40,000
Original Contracts\$39,750
Authorized Change Orders..... NA
Current Contracts \$39,750

2202 Glendale Road Pipeline

Replace aged pipelines within Glendale Road. Project was approved at the regular may Board Meeting. At the July Board meeting, the Board authorized the General Manager to execute a time and materials contract with Ardurra in the amount of \$70,023. Contract has been executed. Consultant completed field survey and prepared 30% design review plans. Staff has completed review and returned comments back to consultant. 90% plan set has been reviewed and returned to consultant. Bid set scheduled to be released mid-November. ~~Next progress step is the 90% review.~~ Schedule is to construct in early 2023.

Original Budget\$276,000
Original Contracts\$70,023
Authorized Change Orders.....NA
Current Contracts\$70,023

2203 Well 31 Pipeline

Project budgeted in the 2022 year. Replace approximately 1,400 linear feet of 14" pipeline from Well 31 delivering water to facilities at Golf Club Drive along backside of homes and within Upland Hills Country Club waterline easement. Abandon aged pipeline. The current steel pipeline was installed before 1976 and has exceeded its useful life. Identified by staff as a high maintenance pipeline.

RFP ~~is being~~ ~~has been~~ prepared and ~~may will~~ be reviewed by PROC this month.

Original Budget	\$420,000
Original Contracts	\$0
Authorized Change Orders.....	NA
Current Contracts	NA

2204 GIS Update

At the August Special Meeting, the Board authorized a contract with WSC to update the Company's GIS maps. Contract has been executed. Consultant working on updates.

Original Budget	\$11,110
Original Contracts	\$11,110
Authorized Change Orders.....	NA
Current Contracts	\$11,110

2205 DWR Supply Assessment

The State of California has implemented new laws in response to statewide water supply shortfalls. One such law requires water suppliers to submit annual reports to the Department of Water Resources regarding supply and demand projections. The annual report is based on the Company's Water Shortage Contingency Plan (also mandated by the State), which was completed by WSC last year. Staff requested WSC's assistance in completing this first Water Supply and Demand Assessment. The contract was within GM's spending authority and a contract has been executed. Supply Assessment has been completed and appropriate data has been submitted to the State.

Original Budget	\$8,980
Original Contracts	\$8,980
Authorized Change Orders.....	NA
Current Contracts	\$8,980

2206 DWR Supply Assessment

The State of California has implemented new laws in response to statewide water supply shortfalls. One such law requires water suppliers to submit annual audits of the Company's supply and demand the Department of Water Resources. This audit is in addition to the mandated Supply Assessment just completed. Staff requested WSC's assistance in completing this first audit. The contract was within GM's spending authority and a contract has been executed.

<u>Original Budget</u>	<u>\$3,665</u>
<u>Original Contracts</u>	<u>\$3,665</u>
<u>Authorized Change Orders.....</u>	<u>NA</u>
<u>Current Contracts</u>	<u>\$3,665</u>

Item Title: Paloma Curve Hydraulic Break

Purpose:

To discuss a draft report from WSC for modernizing the Paloma Curve Hydraulic Break.

Issues:

Should the PROC recommend one of the proposed solutions to modernize the Paloma Curve Hydraulic Break?

Manager's Recommendation:

Recommend forwarding a recommendation to the full Board for Option B as described in attached report.

Background:

The Paloma Curve Hydraulic Break consists of a hydrogenator plant owned by the City of Upland and a concrete Hydraulic Break owned by the Company. The facility is designed to convert hydraulic energy into electrical energy and remove any remaining hydraulic energy prior to discharge at the Company's Reservoir Number Four.

During periods of high-water flow (sustained average-or-higher rainfall events) the amount of water flowing through the facility can create significant low frequency vibrations. These events occur only periodically (once every couple of years). The current property owner has requested that the Company eliminate the noise and/or abandon the facility.

Last year staff started reviewing the Paloma Hydraulic Break, including discussions with the current homeowner. The following solutions are currently being considered:

- Replace metal roof with concrete and install low frequency dampening devices within chamber. Unfortunately, low frequency noise is the hardest to dampen and significant (expensive) sound proofing would not be completely effective.
- Replace hydraulic break with a connector pipeline on current site. Probably the least expensive option but requires maintaining facilities on private property w/ easement.
- Replace entire facility with a pipeline within Paloma Drive. Probably the most expensive option but removes all Company facilities from private property. Would need to coordinate with City to see if they would be willing to abandon their building.

The concrete roof solution requires structural and sound engineering. The two solutions that involve eliminating the Paloma hydraulic break need detailed engineering analysis to ensure continued functioning of the pipeline and reservoir.

The Board awarded a contract to WSC Engineering in March of 2022 to conduct a predesign study and propose solutions. The study is attached.

Alternatives 1 and 2 are the preferred staff solutions. The better value is Alternative 1 if the cost estimate is accurate. A roughly doubling of the construction cost would modernize the entire pipeline.

Alternative 1 is attractive because this option would relocate the entire line out of backyards and along waterways. Staff is concerned about the project cost accurately reflecting current market conditions. If

Agenda Date: October 25, 2022

the committee or Board is inclined, staff would support further study to firm up the estimated cost of this alternative.

Because it is the less expensive option, Staff is tentatively recommending Alternative 2, relocate existing pipeline out of the hydraulic break and into right-of-way. Install larger diameter piping downstream of hydraulic break and modify Reservoir 4 inlet.

Previous Action:

Award of a \$40,000 not-to-exceed predesign contract to WSC Engineering

Impact on Budget:

\$40,000 study

Full project cost is being developed

Technical Memorandum

Date: 10/6/2022

To: Brian Lee
San Antonio Water Company

Prepared by: Patricia Olivas, EIT

Reviewed by: Kirsten Plonka, PE

Project: Paloma Curve Hydraulic Break

SUBJECT: HYDRAULIC BREAK ALTERNATIVE ANALYSIS TECHNICAL MEMORANDUM

The San Antonio Water Company (SAWCo) contracted with Water Systems Consulting, Inc. (WSC) to evaluate the existing Paloma Curve Hydraulic Break (hydraulic break) and identify alternatives to reduce sound and vibrations experienced at the site, while optimizing system operations. The existing hydraulic break is located adjacent to a City of Upland (City) hydrogenerator plant, both of which are located on a residential property. SAWCo maintains a perpetual easement to access their facilities on this property. The City's hydrogenerator plant is no longer used, but SAWCo's irrigation main still runs through the facility into the hydraulic break. The current property owner has raised concerns pertaining to the level of noise and vibrations produced by SAWCo's hydraulic break facility.

This Technical Memorandum (TM) evaluates three alternatives to eliminate the deep vibration and sound experienced at the hydraulic break property, while striving to optimize system efficiency and cost.

1 Introduction and Background

The Paloma Curve Hydraulic Break (Hydraulic Break) is located at the corner of Paloma Curve and Park Boulevard, within the unincorporated community of San Antonio Heights. SAWCo previously owned this property before selling it in the 1980s. When sold, a perpetual easement was established to ensure SAWCo access to its facility. This easement remains in effect today.

The current property owner experiences vibrations and noise during periods of high flow and has requested that SAWCo eliminate the vibrations and noise by abandoning the facility. This is not feasible as the hydraulic break and pipeline that runs through it supplies SAWCo's irrigation system and conveys water into Reservoir 4 and to its shareholders.

In an effort to reduce distress to the current property owner, this analysis strives to find a solution that will benefit both SAWCo and the current property owner where the hydraulic break is located. This TM documents the existing conditions and identifies three alternatives to reduce vibrations and noise from the hydraulic break facility while ensuring SAWCo can continue to operate and provide service to its shareholders.

2 Existing Conditions

The Paloma Curve Hydraulic Break (Hydraulic Break) consists of a hydrogenerator plant owned by the City of Upland and a concrete hydraulic break vault owned by SAWCo. The hydrogenerator facility is no longer used by the City of Upland but remains onsite. The Hydraulic Break is composed of a concrete vault below ground and metal siding above ground, as shown in Figure 1. The estimated footprint of the vault is 11-feet by 15-feet.

These facilities are located on a residential parcel where SAWCo obtains a perpetual easement. Irrigation water is conveyed through the existing 22-inch steel pipeline from SAWCo's Forebay through the Hydraulic Break, at an estimated velocity of 11 feet per second (fps). The estimated drop in pressure between these two facilities is approximately 126 pounds per square inch (psi). As irrigation water, it is common for SAWCo to find large branches and debris in the irrigation system.



Figure 1. Existing Hydraulic Break Facility

3 System Evaluation

Several possible alternatives to reduce noise, vibration, and improve SAWCo’s operations were identified for evaluation. These alternatives are summarized in Table 1 and discussed in further detail below.

Table 1. Evaluation Alternatives

Alternative	Description	Advantages	Disadvantages
1	Relocate the existing pipeline out of the hydraulic break and into right-of-way. Install valves and screening.	<ul style="list-style-type: none"> Reduce noise at existing property Valves will allow for operational flexibility and to mitigate against high pressures. 	<ul style="list-style-type: none"> Screening is required for valves to work successfully. This will increase maintenance as the debris will have to be regularly cleared. Costly to relocate entire large-diameter main into right-of-way.
2	Relocate existing pipeline out of the hydraulic break and into right-of-way. Install larger diameter piping downstream of hydraulic break and modify Reservoir 4 inlet.	<ul style="list-style-type: none"> Reduce noise at existing property. Provide mixing at Reservoir 4 Low maintenance effort 	<ul style="list-style-type: none"> Costly to construct large-diameter main. Space available in right-of-way could potentially be limited by existing utilities.
3	<p>Perform sound attenuation by replacing existing metal walls/roof with a concrete cover.</p> <p>Consider construction of additional vault to provide noise buffer.</p>	<ul style="list-style-type: none"> Reduce noise at existing property. Above ground sound attenuation is cost-effective. 	<ul style="list-style-type: none"> Amount of sound reduction is unknown. Construction of additional vault below-ground may not completely eliminate deep vibrations and may be costly.

Alternative 1

SAWCo may consider relocating the existing pipeline from the hydraulic break into local right-of-way. It is estimated that this alternative will move the existing pipeline 30 – 50 feet away from its existing location, and approximately 15 feet from the property line. Based on these distances, it is anticipated that noise will be reduced. Actual distance from the existing facility, property line and pipeline placement are subject to space constraints within local right-of-way to avoid conflicts with existing utilities.

With the loss of the hydraulic break, SAWCo will likely need to implement additional mechanisms to ensure smooth operations. It is recommended that a pressure reducing valve is installed in lieu of the hydraulic break to help regulate pressures. To avoid clogging or breaking valves, screening should be considered to help filter debris. Potential locations to implement screening include the following locations, also shown in Figure 2:

- San Antonio Creek Inlet
- V-Screen Pump Station
- Forebay

San Antonio Creek Inlet: SAWCo's irrigation system is supplied by surface water from the San Antonio Creek. At the Edison Box, San Antonio Creek water is diverted and split between SAWCo and the City of Pomona (Pomona). SAWCo is entitled to flows above 21.5 Miner's Inches (approximately 200 gpm), and then the diversion is split 60 percent to SAWCo and 40 percent to Pomona. During high flows, Pomona's allocations caps at 312 Miner's Inches (2,915 gpm), and additional flows are allocated to SAWCo up to its maximum allocation. Further investigation of this structure should be conducted to determine if it is a feasible location to install screening and reduce debris within irrigation mains. Screening may be as simple as a catch basin to capture debris prior to entering SAWCo's pipeline.

V-Screen Pump Station: The V-Screen Pump Station boosts domestic water to the northern portion of the San Antonio Canyon. A 20-inch irrigation main runs parallel to this facility. Depending on the required modifications, SAWCo may consider installing screening at this facility to filter out debris from the San Antonio Creek water within the irrigation mainline.

Forebay: SAWCo's Forebay facility is a critical piece of infrastructure for its domestic system. At the Forebay, San Antonio Tunnel (Tunnel) water enters the domestic distribution system. In periods of high Tunnel water inflow, excess Tunnel water can be conveyed into the irrigation system by means of a weir. This helps SAWCo to avoid high-quality water loss. At the Forebay, several irrigation mains disperse into various parts of the system, including the 22-inch main that conveys water to the Hydraulic Break.

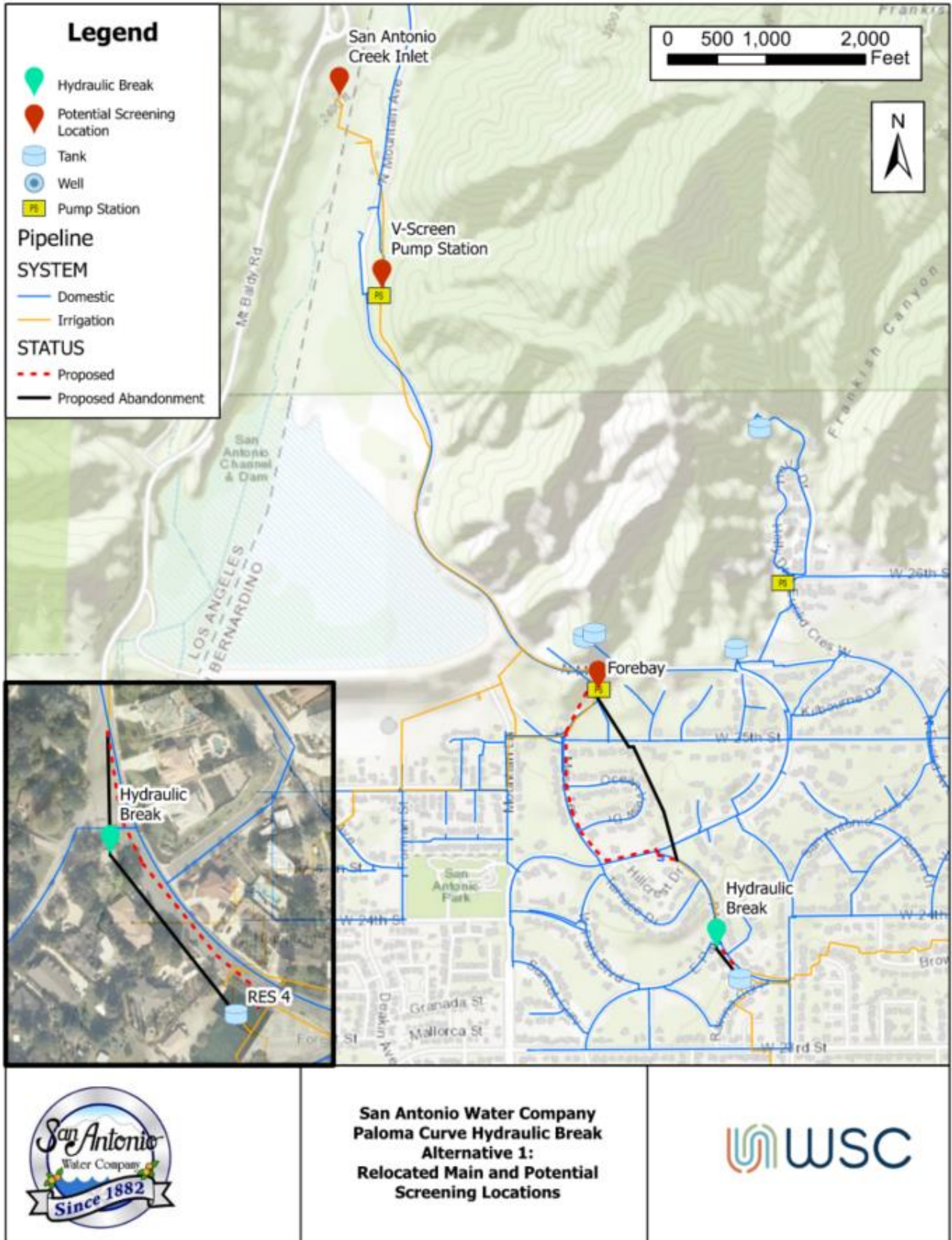

Figure 2. Proposed relocated main and screening locations

It is anticipated that relocating the existing 22-inch main into right-of-way for its entire alignment is likely not cost effective, due to the size and length required. However, much of this main is located within private property and is estimated to have exceeded its estimated end of useful life. SAWCo may wish to relocate this main to improve access to infrastructure and abandon the aging infrastructure within private property.

Alternative 2

SAWCo may consider relocating the existing pipeline from the hydraulic break into local right-of-way and modifying the inlet at Reservoir 4 to provide the necessary break in pressure. As noted in the previous alternative, it is estimated that the existing pipeline may be moved 30 – 50 feet away from its existing location and approximately 15 feet from the property line. Based on these distances, it is anticipated that noise will be reduced. Actual distance from the existing facility, property line and pipeline placement are subject to space constraints within local right-of-way to avoid conflicts with existing utilities.

It is recommended that a 30-inch high density polyethylene (HDPE) main is constructed from the intersection of Park Blvd and Paloma Curve to Reservoir 4. A larger-diameter pipeline will help reduce velocity and therefore reduce noise and vibrations. The inlet at Reservoir 4 will need to be expanded for the 30-inch main or a new inlet should be constructed. Currently, Reservoir 4 experiences relatively stagnant water in the southern portion of the reservoir. It is recommended that SAWCo construct an inlet at the southern end of the reservoir to increase mixing and water quality. The proposed realignment of this pipeline is provided in Figure 3.

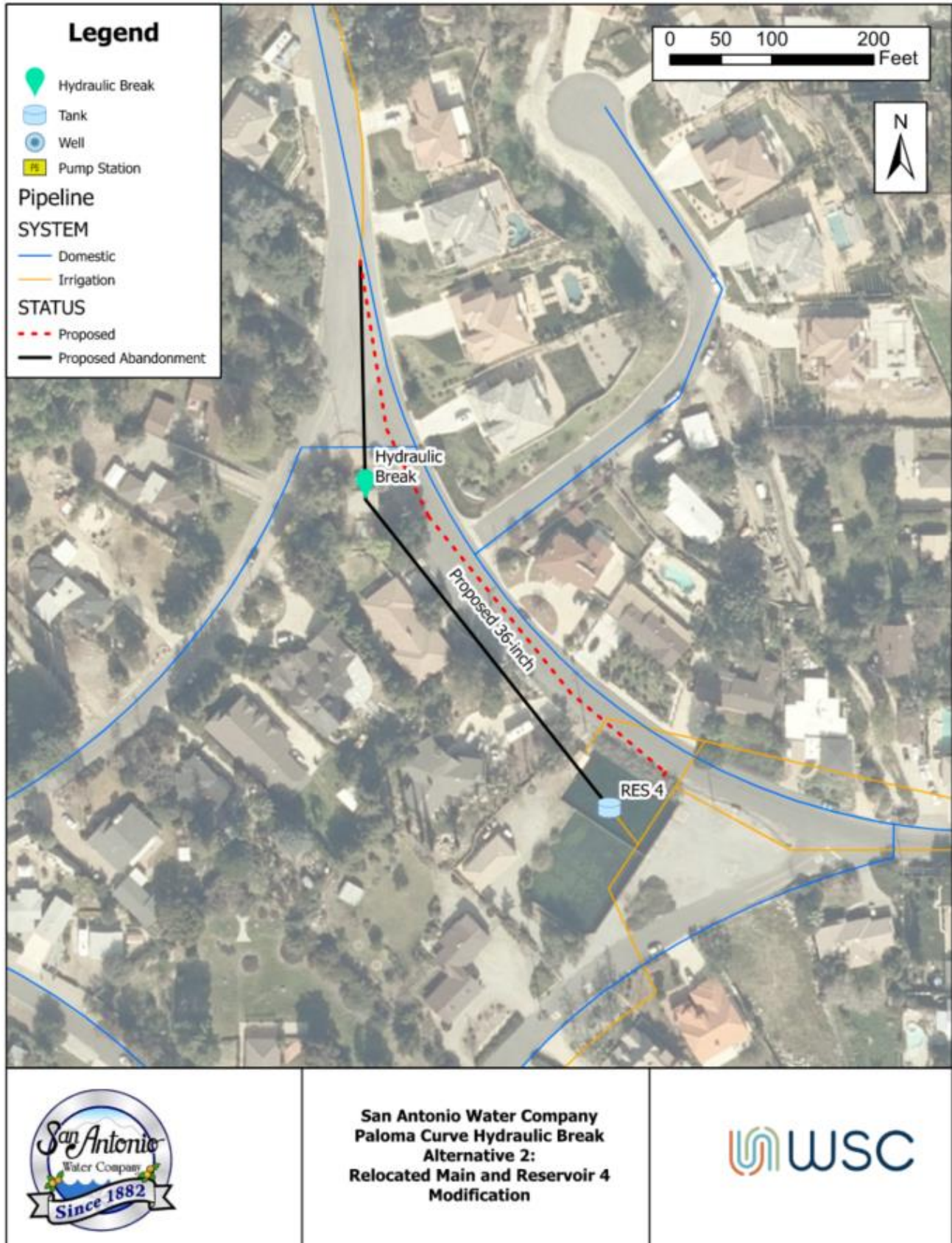

Figure 3. Relocated main into local right-of-way and Reservoir 4 modifications

10/6/2022

Alternative 3

3a - Above-Ground Sound Attenuation

SAWCo may elect to perform sound attenuation to the existing facility to help reduce noise. The existing facility is composed of sheets of metal for the above-ground portion (walls and roof). This material is not very useful for mitigating sound impacts and should be considered for replacement. Other materials, such as a concrete cover, will be much more successful at reducing sound, while allowing SAWCo to continue operations as usual. However, the amount of noise reduction provided by a concrete cover is not guaranteed to eliminate all noise or vibrations from this facility.

3b – Below-Ground Sound Attenuation

Additionally, SAWCo may consider constructing an additional concrete vault around the existing facility to provide space for noise generated by the facility to dissipate. Dimensions for this study are estimated based on the current facility footprint. It was assumed that existing facility has a depth of 10-feet. It is not clear if this will also eliminate vibrations produced at this location.



Figure 4. Proposed plan of additional concrete vault around existing facility.

4 Planning Level Cost

Planning level costs for each alternative were estimated and are summarized in Table 2. Detailed cost breakdowns for each alternative are provided as an attachment to this TM.

Table 2. Estimated Cost for each Alternative

Alternative	Description	Estimated Cost
1	Relocate the existing pipeline out of the hydraulic break and into right-of-way. Install valves and screening.	\$1,069,300
2	Relocate existing pipeline out of the hydraulic break and into right-of-way. Install larger diameter piping downstream of hydraulic break and modify Reservoir 4 inlet.	\$406,900
3a	Perform sound attenuation by replacing existing metal walls/roof with a concrete cover.	\$9,400
3b	Perform sound attenuation by replacing existing metal walls/roof with a concrete cover. Construct additional vault to provide noise buffer.	\$33,400

5 Conclusions

There is no clear alternative that is best suited for this unique facility. Each alternative identified above has advantages and disadvantages that impact SAWCo operations. Sound attenuation identified in alternative 3 is the most cost-effective solution and will not require any changes to typical operations. However, it is unclear how much noise and deep vibrations will be reduced with the improvements identified in alternative 3.

Alternative 2 is expected to provide greater benefits to both the existing property owner and water quality at Reservoir 4. It is estimated that by constructing a larger replacement pipeline within the local right-of-way will help reduce noise and deep vibrations at the existing site.

SAWCo plans to coordinate with the existing homeowner and their acoustics engineer to gain feedback on the alternatives identified above and find a solution that works best for all parties involved.

6 Attachments

- Attachment 1: Cost Estimates

Attachment 1: Cost Estimates

Attachment 1: Cost Estimates

Client: San Antonio Water Company
 Project: Paloma Curve Hydraulic Break Alternatives
 Prepared By: PO
 Reviewed By: KP
 Date: 10/5/2022



A	1	Opinion of Probable Construction Cost
---	---	---------------------------------------

Item Description	Quantity	Units	Unit Cost	Total Item Cost
Sawcut & Remove	2,792	S.Y.	\$10.39	\$29,100
Hauling Pavement	233	L.C.Y.	\$7.69	\$1,800
Pavement Repair	252	Ton	\$250.00	\$63,000
Shoring	40,200	SF Wall	\$0.66	\$26,600
Excavation-Trench	2,606	B.C.Y.	\$8.88	\$23,200
Pipe Bedding (sand import)	1,096	L.C.Y.	\$25.55	\$28,100
Bedding Compaction	1,096	E.C.Y.	\$4.10	\$4,500
Native Backfill & Compaction	1,510	E.C.Y.	\$4.74	\$7,200
Water Compaction	1,510	E.C.Y.	\$1.90	\$2,900
Hauling Excavation	3,127	B.C.Y.	\$5.31	\$16,700
24" HDPE Piping	3,350	L.F.	\$114.09	\$382,300
24" Tee	1	Ea.	\$14,992.63	\$15,000
Cut and Cap	4	Ea.	\$1,000.00	\$4,000
Pipeline Testing & Disinfection	3,350	L.F.	\$1.50	\$5,100
24" Pressure Relief Valve	1	L.S.	\$50,000.00	\$50,000
Install catch basin/screening	1	L.S.	\$5,000.00	\$5,000

Segment Label	Laterals	Diam in	Depth ft
A-1	0	24	6.0

Mobilization	3%	\$20,000
SWPP (per LF) \$	5	\$16,800
Traffic Control (per Day) \$	500	\$11,500
	Subtotal	\$712,800
	Construction Contingency 20%	\$142,600
	Construction Total	\$855,400
	Project Development 25%	\$213,900
	Project Cost	\$1,069,300

Note:
 1. Costs are preliminary and may not represent actual project items.

Attachment 1: Cost Estimates

Client: San Antonio Water Company
 Project: Paloma Curve Hydraulic Break Alternatives
 Prepared By: PO
 Reviewed By: KP
 Date: 10/5/2022



A 2 Opinion of Probable Construction Cost

Item Description	Quantity	Units	Unit Cost	Total Item Cost
Sawcut & Remove	533	S.Y.	\$10.39	\$5,600
Hauling Pavement	44	L.C.Y.	\$7.69	\$400
Pavement Repair	45	Ton	\$250.00	\$11,300
Shoring	7,200	SF Wall	\$0.66	\$4,800
Excavation-Trench	533	B.C.Y.	\$8.88	\$4,800
Pipe Bedding (sand import)	242	L.C.Y.	\$25.55	\$6,200
Bedding Compaction	242	E.C.Y.	\$4.10	\$1,000
Native Backfill & Compaction	291	E.C.Y.	\$4.74	\$1,400
Water Compaction	291	E.C.Y.	\$1.90	\$600
Hauling Excavation	640	B.C.Y.	\$5.31	\$3,400
30" HDPE Piping	600	L.F.	\$90.00	\$54,000
30" 90 Bend	5	Ea.	\$9,000.00	\$45,000
Cut and Cap	2	Ea.	\$1,000.00	\$2,000
Pipeline Testing & Disinfection	600	L.F.	\$1.50	\$900
Temporary Tank	1	L.S.	\$116,500.00	\$116,500

Segment Label	Laterals	Diam in	Depth ft
A-2	0	30	6.0

Mobilization	3%	\$7,800
SWPP (per LF) \$	5	\$3,000
Traffic Control (per Day) \$	500	\$2,500
Subtotal		\$271,200
Construction Contingency 20%		\$54,300
Construction Total		\$325,500
Project Development 25%		\$81,400
Project Cost		\$406,900

Note:

1. Costs are preliminary and may not represent actual project items.
2. Costs for all bends and a reducer included under 90 Bend item.

Attachment 1: Cost Estimates

Client: San Antonio Water Company
 Project: Paloma Curve Hydraulic Break Alternatives
 Prepared By: PO
 Reviewed By: KP
 Date: 10/5/2022



A 3a Opinion of Probable Construction Cost

Item Description	Quantity	Units	Unit Cost	Total Item Cost
Remove existing steel panels	1	LS	\$5,000.00	\$5,000
Reinforced Concrete Cover, 3000 psi Mix	7	CY	\$129.50	\$1,000

Segment Label	Laterals	Diam in	Depth ft
A-3a	0	0	6.0

Mobilization	3%	\$200
Subtotal		\$6,200
Construction Contingency 20%		\$1,300
Construction Total		\$7,500
Project Development 25%		\$1,900
Project Cost		\$9,400

Note:

1. Costs are preliminary and may not represent actual project items.

Attachment 1: Cost Estimates

Client: San Antonio Water Company
 Project: Paloma Curve Hydraulic Break Alternatives
 Prepared By: PO
 Reviewed By: KP
 Date: 10/5/2022



A 3b Opinion of Probable Construction Cost

Item Description	Quantity	Units	Unit Cost	Total Item Cost
Remove existing steel panels	1	LS	\$5,000.00	\$5,000
Reinforced Concrete Cover, 3000 psi Mix	7	CY	\$129.50	\$1,000
Reinforced Concrete Vault, 3000 psi Mix	100	CY	\$129.50	\$13,000
Excavation	90	B.C.Y.	\$8.88	\$800
Hauling Excavation	108	L.C.Y.	\$7.69	\$900
Shoring	640	SF Wall	\$0.66	\$500
Native Backfill & Compaction	52	E.C.Y	\$4.74	\$300

Segment Label	Laterals	Diam in	Depth ft
A-3a	0	0	6.0

Mobilization	3%	\$700
Subtotal		\$22,200
Construction Contingency 20%		\$4,500
Construction Total		\$26,700
Project Development 25%		\$6,700
Project Cost		\$33,400

Note:
 1. Costs are preliminary and may not represent actual project items.

Agenda Date: October 25, 2022

Agenda Item No. 6C

Item Title: Company Treatment Plant

Purpose:

To review a budgetary report of a proposed company treatment plant.

Issues:

Should the Company consider building a water treatment plant?

Manager's Recommendation:

Review report and provide direction to Board.

Background:

The Company's main irrigation system primarily receives water from surface water diversions in the San Antonio Canyon. Most of the irrigation water is provided to the City of Upland's treatment plant located just below the San Antonio Canyon dam. The city's treatment plant has a minimum operating limit of 1.0 MGD. This restriction makes it difficult for the City to receive their full entitlement of SAWCO water when canyon flows seasonally dip and in extended periods of drought.

In September of 2021 the Board awarded a contract to TKE Engineering for preparation of a budgetary study of a possible treatment plant. The draft report is attached for Committee review.

Previous Action: September 21, 2021 - Board awarded a not-to-exceed \$24,500 contract to TKE Engineering

Impact on Budget: To be developed

Budgetary Study For A 1.0 MGD Surface Water Treatment Plant

DRAFT

September 2022

Prepared For:



San Antonio Water Company
139 N. Euclid Avenue
Upland, CA 91786

Prepared By:



TKE Engineering, Inc.
2305 Chicago Avenue
Riverside, CA 92507

Table of Contents

1. Introduction
2. Objectives
3. Project Approach
4. Site Location Evaluation
5. Surface Water Flows and Water Quality Data
6. Surface Water Filtration System
7. Water Disinfection System
8. Final Water Treatment Plant Alternatives Recommendation
9. Operation and Maintenance Cost Analysis
10. Conclusion

List of Tables:

Table 1: Historical Flow Data

Table 2: Summary of Flows

Table 3: San Antonio Creek Water Quality Summary

Table 4: Filtration Systems Comparison

Table 5: Pros and Cons of Chlorine Disinfection and UV

Table 6: UV Disinfection Systems Comparison

Table 7: Alternative 1 -SAWCo WTP Initial Capital Cost Estimate

Table 8: Alternative 2 -SAWCo WTP Initial Capital Cost Estimate

Table 9: WTP O&M Cost Summary

List of Exhibits/Figures:

Figure 1: Wes-Tech Trident System Typical Section View

Figure 2: AWC AC Clarifier System Typical Section View

Figure 3: Napier-Reid Pressure Filtration System Typical Section View

Appendices:

Appendix A: Proposed Site Layout Exhibits

- Exhibit 1 – Alternative 1
- Exhibit 2 – Alternative 2

Appendix B: O&M Cost Tables

Appendix C: Manufacturers Information

1. Introduction

San Antonio Water Company (SAWCo) is a private water purveyor that operates approximately 35 miles east of Los Angeles along the base of the San Gabriel Mountain range, providing water to their shareholders from multiple supply sources which include three separate groundwater basins, groundwater from the San Antonio Tunnel, and surface water runoff from both the San Antonio Creek and the Cucamonga Creek. Two of SAWCo's current largest shareholders being City of Upland and San Antonio Heights.

SAWCo is currently entitled to 60% of the surface water runoff coming from the San Antonio Creek; which is collected at what is known as the middle intake where a portion is then diverted via penstock to the Edison Power Plant and later discharged to the Edison Box. The rest of the surface water not diverted by the Edison penstock continues through the middle intake to the Edison Pond where it flows via stream bed to the Edison Box and eventually is joined with the flows discharged from the Edison Power Plant. From the Edison Box, surface water flows are diverted to the appropriate agencies that they are entitled to, 60% going to SAWCo and the remaining 40% going to the City of Pomona. SAWCo's portion of the surface water from San Antonio Creek then flows from the Edison Box to SAWCo's V-Screen Station where it is either sent to the City of Upland's Water Treatment Plant (WTP) or sent directly to SAWCo's irrigation storage reservoirs, depending on the flow volume.

When the surface water flows from the San Antonio Creek are above 1.0 million gallons per day (MGD), SAWCo diverts the majority of their entitlement to the City of Upland's WTP located at the base of the San Antonio Dam, where it is treated and used in SAWCO's domestic system to supply their shareholders with potable water, including the City of Upland. Unfortunately, the City of Upland's WTP has a minimum operating capacity of 1.0 MGD which makes it difficult for SAWCo to provide the City of Upland with their full share of surface water from San Antonio Creek under low flow conditions. When surface water flows fall below 1.0 MGD, they are directed to irrigation box located at SAWCo's Forebay facility then distributed to storage reservoirs until the water will be used either to replenish ground water basins or to meet any irrigation demands.

SAWCo desires to evaluate the different treatment alternatives and the feasibility for a proposed 1.0 MGD Surface Water Treatment Plant to be operated in times when the surface water runoff from San Antonio Creek is below 1.0 MGD (i.e., too low to be directed to the City of Upland's WTP). The proposed WTP would allow for SAWCo to maximize their 60% entitlement of the San Antonio Creek surface water to be used in their domestic system and help meet the growing potable water demand from their shareholders.

2. Objectives

The primary objective of this budgetary study is to evaluate the feasibility of a 1.0 MGD surface water treatment plant, to be constructed and operated by SAWCo. More specifically, the scope of this study is to evaluate the historical flows and water quality data, provided by SAWCo, to identify viable surface water treatment alternatives and provide a recommendation of the best potential alternative based on treatment capability, required footprint, and overall initial capital cost; as well as provide an estimated operation and maintenance (O&M) cost of the preferred alternative for long range planning.

This report presents and compares three different surface water filtration systems alternatives; as well as three different UV disinfection system alternatives so that the surface water can be discharged directly into SAWCo's domestic (potable) water system. For the preferred alternative, a preliminary site layout exhibit, initial capital cost estimate and estimated O&M costs are provided.

3. Project Approach

In this budgetary study, TKE evaluated the historical flow data from the past 10-years to determine the frequency of San Antonio Creek surface water flows below 1.0 MGD. From this data, we were able to determine how often the proposed SAWCo WTP would potentially be operational throughout the year. This helps provided justification for the need for a 1.0 MGD WTP, as well as aid in estimating the potential O&M costs associated with the proposed WTP. Using the flow data and the water quality data provided by SAWCo, TKE researched different treatment technologies suited to the expected surface water quality, flows, and the planned usage of the WTP (i.e., intermittently). After narrowing down viable surface water filtration systems alternatives, TKE coordinated directly with the manufactures to verify proposed filtration system details, including the size and number of treatment trains that would be the most efficient for the expected range of flows and the water quality data.

4. Site Location Evaluation

The preferred location for SAWCo's proposed 1.0 MGD WTP would be on the same property as the existing SAWCo Forebay Facility; however, due to the existing site layout and natural terrain, the available space for the new treatment equipment is limited and could potentially require the site to be expanded. As such, WTP alternatives with a small footprint that can still effectively treat the surface water conditions while providing the lowest cost are preferred.

The existing SAWCo Forebay Facility site provides four main benefits as the proposed WTP site location. The first being the existing irrigation conveyance system that currently receives surface water from San Antonio Creek through the Forebay Facility via gravity. This would allow for raw surface water to be supplied to the proposed WTP through the means of an existing effluent pipe that would connect to the existing irrigation main, eliminating the need to construct a separate conveyance system to

deliver water to the proposed WTP. The second benefit being that the Forebay Facility has an existing direct connection to SAWCo’s domestic system to deliver the treated water to customers. The third benefit is that the Forebay Facility can provide potable water to be used for the proposed filter systems backwash cycle. The fourth benefit is the existing irrigation box, located within the Forebay Facility, could potentially eliminate the need to construct backwash storage and settling tanks. During a backwash cycle, the backwash water can be discharged directly to the irrigation box to be distributed to SAWCo’s existing irrigation storage reservoirs; thus, reducing the overall required footprint and initial capital cost of the proposed WTP. Providing alternatives that will work within the identified site constraints are preferred.

5. Surface Water Flows and Water Quality Data

The first step of the analysis was to evaluate the historical flows that SAWCo has experienced from San Antonio Creek and determine how often surface water flows fall below 1.0 MGD. For this, TKE evaluated the monthly flow measurements provided by SAWCo and converted the measurements to show the average daily flow per month in MGD over the past 10 years. Using this data, we were able to determine the number of months that the surface water flow dropped below 1.0 MGD. The historical flow data is presented in **Table 1** below.

Table 1
Historical Flow Data

Year	Jan. (MGD)	Feb. (MGD)	Mar. (MGD)	Apr. (MGD)	May (MGD)	Jun. (MGD)	Jul. (MGD)	Aug. (MGD)	Sep. (MGD)	Oct. (MGD)	Nov. (MGD)	Dec. (MGD)
2012	3.33	3.00	3.51	4.01	4.13	2.80	1.94	1.55	1.23	1.01	1.12	1.58
2013	1.71	1.93	1.99	1.82	1.69	1.23	1.11	0.95	0.79	0.73	0.74	0.86
2014	0.97	1.09	2.53	1.73	1.15	1.08	1.14	1.62	1.25	1.20	1.40	2.57
2015	2.31	2.25	2.23	2.89	2.87	1.40	1.49	1.42	1.51	1.35	1.01	0.97
2016	1.67	2.35	2.52	2.31	1.96	1.44	0.99	0.92	0.32	0.57	0.46	1.00
2017	5.55	9.35	14.25	13.74	8.92	5.49	3.41	2.56	2.16	1.48	1.31	1.10
2018	1.44	1.13	2.06	2.19	1.67	1.04	0.66	0.19	0.64	0.42	0.33	0.87
2019	2.83	6.46	12.23	12.86	12.51	11.36	7.31	4.79	3.33	2.65	2.32	4.79
2020	5.51	4.28	6.43	9.55	11.95	11.41	7.50	4.66	3.14	2.41	2.19	1.97
2021	1.95	2.40	2.49	2.07	1.66	1.20	1.04	0.72	0.56	0.50	0.41	0.00

For the purpose of this study, it was assumed that the proposed WTP would need to have the ability to treat flows ranging from 0.19 MGD to 0.99 MGD based on the data presented in the Table 1. The ability to treat this range of flows would allow SAWCo to utilize the greatest amount of their surface water entitlement when treatment at Upland’s WTP is not feasible. In the above table, all the cells shaded grey, show the months where the average surface water flows from San Antonio Creek dropped below 1.0 MGD over the past 10 years. Based on available data, the proposed WTP would potentially be operated about 4-5 months out of the year. Breaking the flow data down further, we were able to determine how often the proposed WTP would operate within a certain flow range. This was done to further aid in the sizing of the proposed WTP, specifically the number of treatment trains that would be best suited to efficiently handle the expected range of flows below 1.0 MGD flows from San

Antonio Creek. **Table 2** highlights the percentage of the year that flows are below 1.0 MGD, 0.75 MGD, 0.50 MGD, and 0.25 MGD.

Table 2
Summary of Flows

Year	Range of Flows (MGD)	Average Flow (MGD)	# of Days Flow are Less than 1 MGD	Percent of Year Flow is Less Than 1 MGD	# of Days Flow are Less than 0.75 MGD	Percent of Year Flow is Less Than 0.75 MGD	# of Days Flow are Less than 0.50 MGD	Percent of Year Flow is Less Than 0.50 MGD	# of Days Flow are Less than 0.25 MGD	Percent of Year Flow is Less Than 0.25 MGD
2012	-	-	-	-	-	-	-	-	-	-
2013	0.73 - 0.95	0.81	153	42%	61	17%	0	0%	0	0%
2014	-	0.97	31	8%	0	0%	0	0%	0	0%
2015	-	0.97	31	8%	0	0%	0	0%	0	0%
2016	0.32 - 0.99	0.65	153	42%	91	25%	60	16%	30	8%
2017	-	-	-	-	-	-	-	-	-	-
2018	0.19 - 0.87	0.52	184	50%	153	42%	92	25%	31	8%
2019	-	-	-	-	-	-	-	-	-	-
2020	-	-	-	-	-	-	-	-	-	-
2021	0.41 - 0.72	0.55	122	33%	122	33%	62	17%	0	0%
Summary of Past 10-years	0.19-0.99	0.66	674	18%	427	12%	214	6%	61	2%

As shown in the table above, the majority of the surface water flows appear to fall between 0.25 MGD and 0.75 MGD. Assuming the majority of the expected flow range would fall between 0.25 MGD and 0.75 MGD, TKE has determined that two filtration treatment trains would be the best option for the proposed WTP. This would give the proposed WTP the flexibility to treat the range of flows more efficiently than a single treatment train. Further, this option would still give SAWCo the ability to operate a single treatment train to treat surface water flows in the event that one of the treatment trains is offline and/or requires maintenance.

SAWCo provided water quality data for the surface water from San Antonio Creek from samples taken from their V-Screen location between the years of 2017 through 2020. The water quality data is summarized in **Table 3** below.

Table 3
San Antonio Creek Water Quality Summary

Analyte	Method	Units	Result				Rep. Limit	MCL
			2017	2018	2019	2020		
Alkalinity, Total (as CaCO ₃)	SM 2320B	mg/L	150	160	150	150	5	
Ammonia as N (NH ₃ -N)	EPA 350.1	mg/L	-	ND	ND	ND	0.5	
Bicarbonate (HCO ₃)	SM 2320B	mg/L	190	190	190	170	5	
Carbonate (CO ₃)	SM 2320B	mg/L	ND	ND	ND	ND	5	
Chloride (Cl)	EPA 300	mg/L	1.5	ND	1.1	1	1	500
Specific Conductance (E.C.)	SM 2510B	umhos/cm	330	320	310	300	2	1600
Fluoride (F)	EPA 300	mg/L	0.29	0.31	0.3	0.34	0.1	2
Hydroxide (OH)	SM 2320B	mg/L	ND	ND	ND	ND	5	
MBAS (LAS Mole. Wt 340.0)	SM 5540C	mg/L	ND	ND	ND	ND	0.1	0.5
Nitrate as N (NO ₃ -N)	EPA 300	mg/L	ND	ND	ND	ND	0.4	10
Nitrite as N (NO ₂ -N)	EPA 300	mg/L	-	ND	ND	ND	0.4	1
Organic Nitrogen	Calculation	mg/L	-	ND	ND	ND	1.5	
pH (Lab)	SM 4500HE	pH Units	7.8	8.3	8.4	8.4		
Sulfate (SO ₄)	EPA 300	mg/L	18	18	20	19	0.5	500
Total Filterable Residue/TDS	SM 2540C	mg/L	230	190	180	170	5	1000
Total Kjeldahl Nitrogen	EPA 351.2	mg/L	-	ND	ND	ND	1	
Total Organic Carbon	SM 5310B	mg/L	-	ND	0.44	ND	0.3	
Turbidity	EPA 180.1	NTU	-	0.6	-	-	0.1	5
Metals								
Boron (B)	EPA 200.7	ug/L	ND	ND	ND	ND	100	
Calcium (Ca)	EPA 200.7	mg/L	49	53	52	49	1	
Copper (Cu)	EPA 200.7	ug/L	ND	ND	ND	ND	50	1000
Iron (Fe)	EPA 200.7	ug/L	100	ND	ND	ND	100	300
Magnesium (Mg)	EPA 200.7	mg/L	7.8	9	8.7	8.3	1	
Manganese (Mn)	EPA 200.7	ug/L	ND	ND	ND	ND	20	50
Potassium (K)	EPA 200.7	mg/L	1.7	1.7	1.9	1.9	1	
Silica (SiO ₂)	EPA 200.7	mg/L	-	17	15	15	0.5	
Sodium (Na)	EPA 200.7	mg/L	4.8	5.1	5.3	4.8	1	
Zinc (Zn)	EPA 200.7	ug/L	ND	ND	ND	ND	50	5000
Anion / Cation Balance								
Hardness, Total (as CaCO ₃)	Calculation	mg/L	160	170	160	160		
Total Anions	Calculation	mg/L	3.55	3.51	3.58	3.23		
Total Cations	Calculation	mg/L	3.34	3.66	3.60	3.39		
% difference	Calculation		5.9	4.2	0.46	4.9		

The water quality data presented above is within the general range of expected surface water quality and does not raise any concerns that may require any form of special treatment. It should be noted, due to the lack of turbidity testing in the water quality data provided, it was assumed for the purpose of this study that the turbidity of the San Antonio Creek surface water would be consistent the results provided in the 2018 samples.

6. Surface Water Filtration System

To treat surface water from San Antonio creek to be used for potable water supply, a filtration system would be required to remove particles, sediment, and harmful constituents and a disinfection system to remove harmful bacteria, virus, and other organisms that may be present in the water. This section focuses on the proposed filtration system. Three potential filtration systems, including a summary of their respective treatment process, are presented below. As described above, due to the site restraints, the preferred filtration system alternative will provide the smallest footprint at the lowest initial cost and can still effectively treat the wide range of surface water conditions.

Filter Alternative 1 – WesTech Trident System

Alternative 1 would consist of two (2) Trident TR-210A units, each with an operating capacity 350 gallons per minutes (gpm) (or 0.50 MGD) to provide a combined operating capacity of 700 gpm (or 1.0 MGD). Each Trident tank is constructed of carbon steel with a Tnemec Pota-Pox coating to prevent corrosion.

WesTech's Trident System is a pre-engineered system consisting of a pretreatment and filtration system contained in a single shippable steel tank. The Trident System utilizes a two-stage configuration containing of an up flow buoyant bead and compressible media adsorption clarifier system followed by a conventional down-flow mixed media filter to produce high quality effluent water. The Trident System is a suitable alternative for surface water filtration and would be more than capable in treating the flows and water quality that SAWCo experiences from San Antonio Creek; however, due to the larger footprint and the overall equipment cost, this would not be the preferred treatment alternative.

Treatment Process

The treatment process starts with chemically dosed raw water entering the adsorption clarifier chamber towards the bottom of the tank to start the up-flow treatment process, which combines flocculation and clarification. Once the water passes through the adsorption clarifier chamber, it flows over a weir into a collection trough to be distributed into the mixed media filtration chamber. After, the water is collected by a multiblock underdrain and the filtered effluent water then exits the Trident unit.

The Trident's adsorption clarifier chamber is programmed to initiate the flush cycle when the headloss in the system indicates that cleaning is required. The adsorption clarifier flush cycle consists of a mixture of air and water which aggressively separates any solids from the media. The solids are then discharged through waste pipes.

The backwash cycle operates in a similar manner to the adsorption clarifier flush cycle. Once the Trident system senses headloss in the mixed media chamber due to dirty and/or clogged media, the Trident will initiate the backwash cycle. Air scour valves and potable (or treated) water are then used to backwash the mixed media in an up-flow process. Solids from the backwash cycle are forced into the collection

trough and discharged out of the system through the waste pipes. This backwash water can be discharged into SAWCo's irrigation box located at the Forebay Facility to be reused as irrigation water.

A sectional view of the Wes-Tech Trident system can be seen in **Figure 1** below.

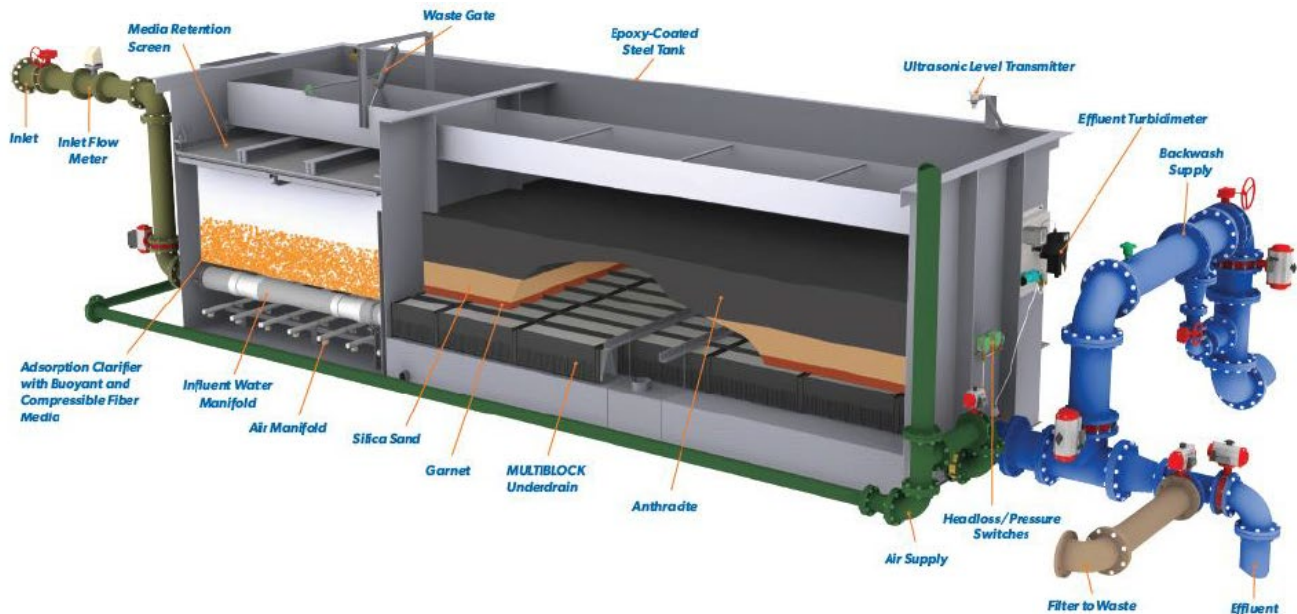

Figure 1: Wes-Tech Trident Treatment System

Filter Alternative 2 – AWC Water Solutions LTD. AC Clarifier:

Alternative 2 would consist of two (2) AWC-AC-350 Clarifier units, each rated at a max operating capacity of 350 gpm (or 0.5 MGD), which would give the proposed WTP a total operating capacity of 700 gpm (or 1.0 MGD). Each AWC AC Clarifier unit is constructed from 1/2" & 3/16" 304 stainless steel plate and 1/4" structural membranes.

AWC's AC Clarifier are a packaged treatment plant option which combine a unique backwash up flow media clarifier that provides a combined flocculation and clarification process as raw water passes through the unit.

Treatment Process

The first step of the treatment process consists of flash mixing in which coagulants are added to the raw water to combine small particles and contaminants, creating larger suspended particles otherwise known as flocs. After the flash mixing flocculation takes place, where the water passes through a clarifier media in an upward flow to partially remove the flocs through the means of a coarse media. This stage acts as both the flocculation and clarification stage which reduces filter loading

as well as the overall footprint of the unit. From there, the water passes through a high-rate media filter through a downflow rapid gravity filtration process to remove any remaining particles and the filtered water is then discharged from the AC unit.

Any solids that were captured by the filter media during the up flow and down flow filtration step are removed during an automatically controlled air/water backwash cycle. First an initial air scour cycle takes place, which is followed by a combined air and water wash cycle. The backwash is completed with a final water only backflush, where backwash water is discharged from the system. This backwash water can be discharged into SAWCo's irrigation box located at the Forebay Facility to be reused as irrigation water.

A typical sectional view of the AC Clarifier unit can be seen in **Figure 2** below.

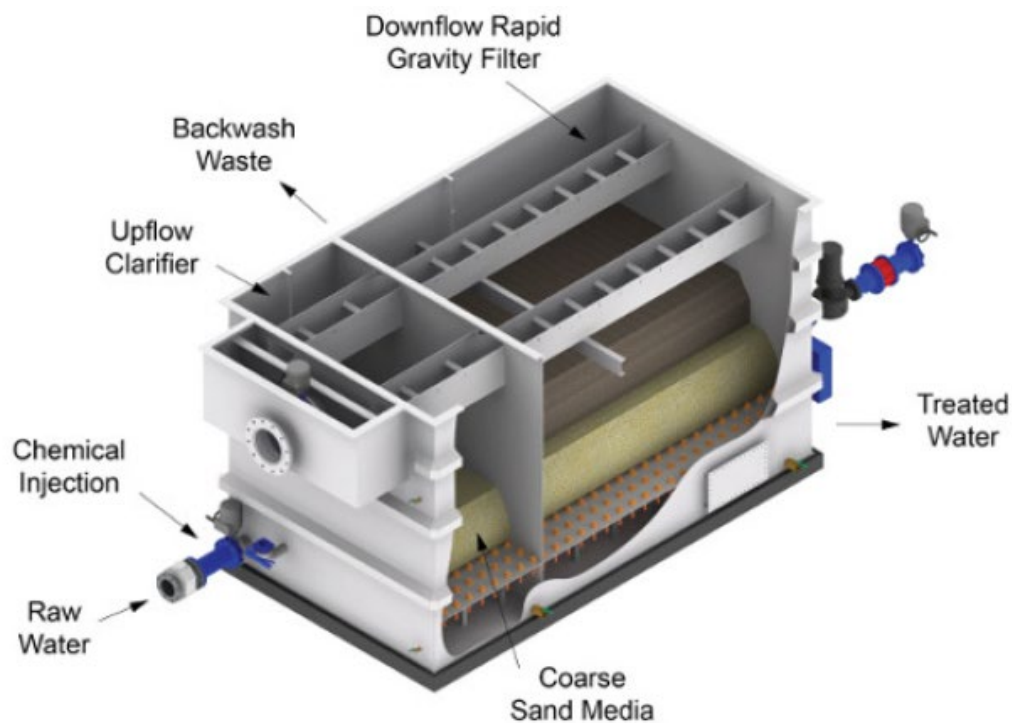

Figure 2: AWC AC Clarifier

Filter Alternative 3 – Napier-Reid Pressure Filtration System:

Alternative 3 would consist of two (2) Napier-Reid free standing multimedia pressure filters, each with a max operating capacity of 350 gpm (or 0.50 MGD) and a total combined operating capacity of 700 gpm (or 1.0 MGD). The pressure filtration tanks are made of epoxy coated carbon steel and are rated for working pressures of 50 pounds per square inch (PSI).

Pressure filtration systems are designed to filter water in a closed vessel/tank under pressurized conditions which results in higher filtration rates, the ability to operate under higher pressure drops and an overall smaller footprint than a conventional gravity filtration system.

Treatment Process

The treatment process for the Napier-Reid pressure filtration system starts with raw surface water entering the vessel and being distributed across the filtration area. The water will then be forced to filter down through the filter bed media layers where dirt, suspended solids, sediment, algae, bacteria, virus, asbestos, color, odor, precipitates of iron, manganese and other impurities will be strained out and captured in the fill depth of the media filter bed, which increases the overall solids handling capacity. The increased solids handling capacity results in longer filter run times and reduces the number of required backwash cycles for the filtration system to operate.

The system is designed to monitor the pressure and detect when the filters require a backwash. When the backwash cycle is initiated, clean water is used to rinse all the entrapped solids and other impurities from the filter media and discharge from the system. This backwash water can be discharged into SAWCo's irrigation box located at the Forebay Facility to be reused as irrigation water.

A typical sectional view of the AC Clarifier unit can be seen in **Figure 3** below.

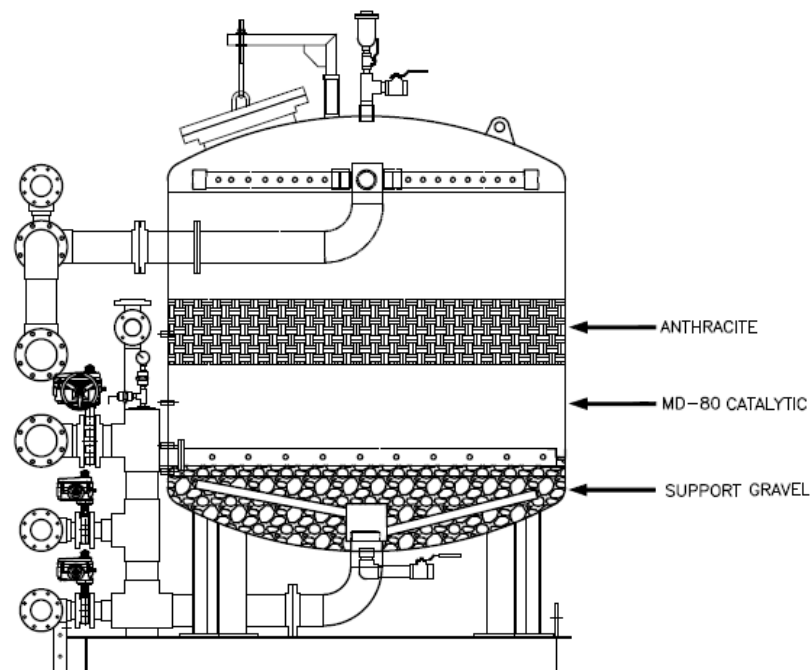

Figure 3: Napier-Reid Pressure Filtration System

Filtration Alternatives Comparison:

**Table 4
Filtration System Comparison**

	WesTech Trident System	AWC AC Clarifier System	Napier Reid Pressure Filtration System
Treatment Type	Adsorption Clarifier	Adsorption Clarifier	Multimedia Pressure Filtration
System Design Flow	700 gpm	700 gpm	694.44 gpm
Project Flow	700 gpm (Max)	700 gpm (Max)	694.44 gpm (Max)
Number of Units	2	2	2
Flow Capacity per Unit	350 gpm	350 gpm	347.22 gpm
Adsorption Clarifier Area	35 ft ² Per Unit	40 ft ² Per Unit	-
Adsorption Clarifier Loading Rate (At Design Flow)	10 gpm/ft ²	8.75 gpm/ft ²	-
Adsorption Clarifier Water Flush Rate	350 gpm	350 gpm	-
Adsorption Clarifier Air Flush Rate	360 scfm (10 scfm/ft ²)	556 scfm	-
Filter Area	70 ft ² Per Unit	96 ft ² Per Unit	71 ft ² Per Unit
Filter Loading Rate (At Design Flow)	5 gpm/ft ²	5 gpm/ft ²	4.9 gpm/ft ²
Backwash Method	Air & Water	Air & Water	Water
Average Backwash Water Loading Rate	10 gpm/ft ²	16 gpm/ft ²	12 gpm/ft ²
Average Backwash Water Flow Rate	700 gpm	1536 gpm	851 gpm
Average Filter Backwash Cycle Frequency	30-35 Hours	24 Hours	12-30 Hours
Average Backwash Cycle Duration	10-15 Mins	6 Mins	7-10 Mins
Air wash Loading Rate	5.0 scfm/ft ²	4.0 scfm/ft ²	-
Air wash Flow Rate	360 scfm	384 scfm	-
Dimensions (Each Unit)	Length: 14 ft 6 in Width: 8 ft 11 in Height: 8 ft 5 in	Length: 17 ft Width: 8 ft Height: 8 ft 6 in	Diameter: 9 ft 6 in Height: 5 ft
Equipment Cost	\$ 655,000.00	\$ 815,150.00	\$ 576,900.00

To treat the surface water from San Antonio Creek when the flows are less than 1.0 MGD, all filter alternatives will utilize two separate treatment trains that will work together to achieve a total operating capacity of 1.0 MGD. A dual train treatment system will allow for the plant to operate with greater efficiency based on the historic flow data presented in **Table 1** and **Table 2**, above. When the surface water flows drop below 0.50 MGD, the proposed plant would be able to operate a single treatment train. When the surface water flows jump above the 0.5 MGD, the second treatment train be used and give the proposed plant a total operating capacity up to 1.0 MGD. This would give SAWCo more flexibility to utilize their full 60% entitlement of the San Antonio Creek surface water runoff. In addition, a dual treatment train would allow for SAWCo to still operate a single treatment train in times when one of the treatment

trains may be off-line and/or require maintenance. The alternatives are summarized and compared in **Table 4** above.

Based on the data presented in the above table, all presented filtration alternatives would have the capability to effectively treat San Antonio Creek surface water runoff. However, based on the lowest base equipment cost and site constraints, Napier-Reid's pressure filtration system is the preferred alternative. As shown in **Table 4**, the Napier-Reid system has a similar filter area and loading rate with the smallest footprint; while maintain a low backwash cycle rate with water only, eliminating the need for an air system. The Napier-Reid system has the lowest base equipment cost; however, it may have the shortest backwash cycle frequency. TKE recommends the backwash cycle frequency be evaluated and confirmed during preliminary design stage to ensure low cycle time wont negatively impact daily operations and long-term O&M.

7. Water Disinfection System

In order to meet the State's Title 22 requirements for potable water, the filtered surface water will require disinfected prior to entering SAWCo's domestic water system. Two disinfection alternatives were initially considered, a chlorine disinfection system and a UV disinfection system. For the purpose of this budgetary study, disinfection alternatives were evaluated on the basis of site constraints, capital cost, ease of operation, and general O&M costs. A pros and cons comparison between chlorine disinfection and UV disinfection is summarized in **Table 5** below.

Table 5
Pros and Cons of Chlorine and UV Disinfection

	Chlorine	UV
Permitting Process	Simple	Could be Complicated
Capital Cost	Lower	Higher
O&M	Higher/Complex Technology	Lower
Safety Measures/Training	Higher	Lower
For Print	Higher	Lower
Foot Print for De-chlorination	Likely Required	Not Required
Addition of Chemical During Disinfection & De-chlorination	Yes (Salts, Especially Sodium)	None
Headloss	Similar to Channel UV	Varies with Systems
Process Description	Oxidation, Modification of Cell Walls, Mechanical Description, Protein Precipitation	Photochemical Damage, Destruction of Cell Walls, Reduced Pathogen Loads to Low Levels

Due to the small amount of usable space on the existing SAWCo Forebay Facility, it might be difficult to provide the footprint needed for a chlorine disinfection system including the required contact time and potential de-chlorination components. As

such, UV disinfection was chosen for further analysis due to its relatively small footprint and ease of operation. In California, a UV disinfection system must deliver a UV dose of 100 mJ/cm². The key to proper UV disinfection system performance is the effective removal of larger particles by the upstream filtration system so that the UV light is not obstructed from the smaller particles. This provides for highly efficient disinfection system to remove harmful bacteria, virus, and other organisms. Three different alternatives for UV disinfection are summarized in **Table 6** below.

Table 6
UV Disinfection Systems Comparison

	ETS-UV an EVOQUA	Aquionics, Inc.	Trojan Technologies
Treatment Capacity (MGD)	0.77 MGD	1.25 MGD	1 MGD
Dose	100 mJ/cm ²	100 mJ/cm ²	100 mJ/cm ²
Structure	In-Line	In-Line	Channel
Model	UVLW	Proline PQ IL	UV Signa
Number of Units	2 units (1 per filtration train)	1 Unit	1 UV bank
Design Flow Per Unit	0.77 MGD	1.25 MGD	1 MGD
Configuration	1 unit	1 unit	1 channel with 1 UV bank
Total Lamp Power to Treat 1 MGD (kW)	30 kW	52kW	15kW
Equipment Head Loss at Design Flow	3-inches	3-inches	5-inches
Total UV System Head Loss	± 42-inches	± 42-inches	± 24-inches
Estimated Foot print (L x W)	17-ft x 12-ft	10-ft x 10-ft	40-ft x 10-ft
Estimated Equipment Cost	\$187,500	\$175,000	\$115,000

The proposed UV disinfection systems were evaluated on equipment cost and required footprint. As shown in the table above, the ETS-UVLW would limit the proposed WTP to a disinfection capability of only 0.77 MGD as well as has the highest equipment cost. Due to these reasons, the system is not recommended. The Aquionics, Inc. Proline PQ IL system would give the proposed WTP the capability of treating the full potential flow of 1.0 MGD as well as requires the smallest overall footprint; however, it also has the second highest base equipment cost. **Figure 4** below shows a typical Aquionics Proline PQ IL system layout. Lastly, the Trojan UV Signa channel system has the lowest equipment cost; however; the equipment cost does not include the cost to construct the required channel which can be costly. The Trojan UV Signa also has the largest footprint and would potentially require the existing site to be substantially expanded. **Figure 5** below shows a typical Trojan UV Signa system layout.

While both the Aquionics Proline PQ IL and Trojan UV Signa Channel Disinfection Systems are viable options, the Aquionics Proline PQ IL system's size and footprint work best within the existing site constraints.



Figure 4: Aquionics Proline PQ IL UV Disinfection System

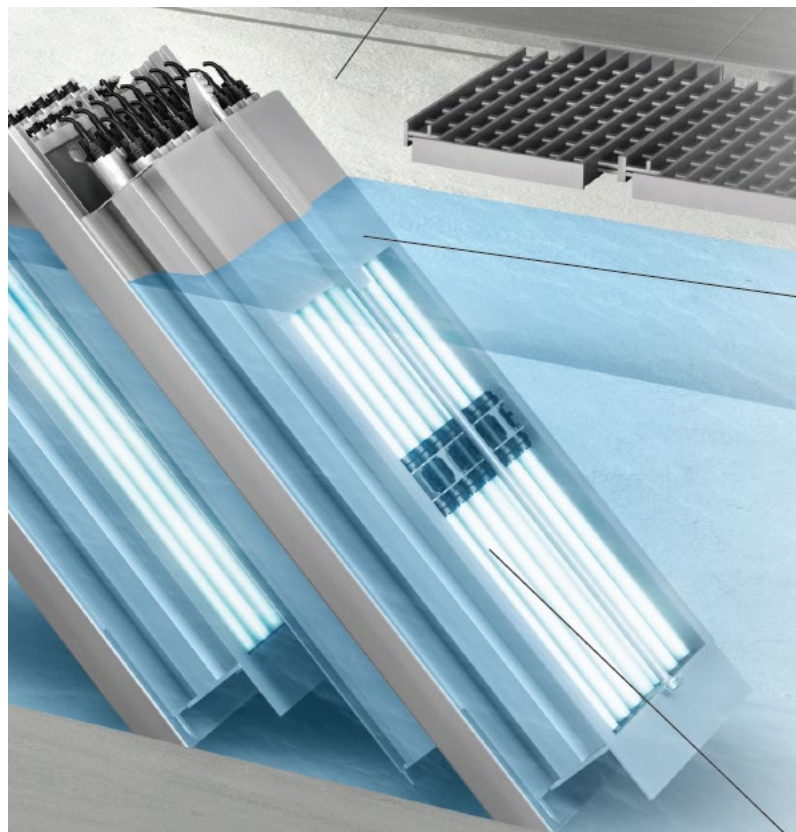

Figure 5: Trojan UV Signa Disinfection System

8. Final Water Treatment Plant Alternatives Recommendation

During preparation of the preliminary site layout exhibits, it was discovered that the site will be required to be expanded regardless of the equipment footprint due to existing site constraints. Additionally, it would also be in the best interest to expand the site so that proper equipment spacing can be used, allowing for better accessibility and greater ease of maintenance.

TKE prepared two alternatives for the proposed SAWCo WTP, both alternatives will utilize the same filtration system but different UV disinfection systems, the Aquionics Proline PQ IL and Trojan UV Signa channel disinfection systems. Two alternatives were prepared to provide a fair comparison between the different UV disinfection systems. The Alternatives and total estimated initial capital costs are summarized below.

Alternative 1 will consist of the Napier-Reid Pressure Filtration System with the Aquionics Proline PQ IL UV Disinfection System. This alternative presents the smallest overall footprint for the proposed WTP. It would require that the existing site be expanded by approximately 1,500 square feet to allow for the pressure filtration system to be constructed on-site without interfering with the existing conveyance lines running through the site. The existing storage building would be repurposed to house the UV disinfection unit and control panel. The site layout for Alternative 1 can be seen in **Exhibit 1**, attached in **Appendix A**. The estimated initial capital cost for this alternative would be \$2,460,000. The full cost estimate breakdown can be seen in **Table 7** below.

Alternative 2 will consist of the Napier-Reid Pressure Filtration System with the Trojan UV Signa Channel System. This would require the existing site to be expanded approximately 2,400 square feet to accommodate both the pressure filtration system as well as the UV disinfection channel system. This alternative does not require that the existing storage building be demolished; however, it can be removed to allow for better access to the proposed equipment. The site layout for Alternative 2 can be seen in **Exhibit 2**, attached in **Appendix A**. The estimated initial capital cost for this alternative would be \$2,500,000. The full cost estimate breakdown can be seen in **Table 8** below.

Of the two alternatives presented above and notwithstanding O&M costs, TKE's preferred alternative is Alternative 1. The proposed Napier Reid Pressure Filtration System with the Aquionics Proline PQ IL UV Disinfection System have the smallest required footprint, repurposes the existing storage building, and provides the lowest initial capital cost. An analysis of the long-term O&M costs for Alternative 1 is presented in the next section.

Table 7
Alternative 1 – SAWCo WTP Initial Capital Cost

No.	Description	Quantity	Unit	Unit Cost	Amount
General					
1	Mobilization/Demobilization, Bonds, Etc.	1	LS	5%	\$ 70,000
2	SWPPP, Best Management Practice	1	LS	\$5,000	\$ 5,000
3	Clearing and Grubbing	1	LS	\$3,000	\$ 3,000
Subtotal:					\$ 78,000
Site Demolition					
4	Remove and Disposal of Various Items	1	LS	\$5,000	\$ 5,000
Subtotal:					\$ 5,000
Site Improvements					
5	Construct Retaining Wall Extension Including Wrought Iron Fence	30	CY	\$1,200	\$ 35,555.56
6	Earthwork: This would include grading of area for the new retaining wall extension including fill.	350	CY	\$15	\$ 5,250.00
7	Construct 3" Asphalt Concrete Paving with 4" of CAB: This will be for the new extended area due to the retaining wall extension.	1,500	SF	\$8	\$ 12,000.00
8	Napier-Reid Pressure Filtration System	1	LS	\$670,000	\$ 670,000
7	Mechanical: This would include unloading & installation filters, automatically control weir gates, all the ancillary equipment not provided in the equipment scope of supply, process piping and connection of backwash, drain, overflow, influent, effluent; field welding, field assembly, ladder and platforms for filters, filling the tank, manufacturer support during installation, testing and operation of filters, weir gates, inspection and final equipment adjustment, gates etc. (at % of Equipment).	1	LS	25%	\$ 168,000
8	Electrical & Instrumentation: Installation of all electrical and instrumentation components, NTU meters, installation of control panels and integration into one system, integration of weir gates control, programming and connection to SCADA (at % of mechanical).	1	LS	20%	\$ 134,000
9	In Line Coagulation injection system	1	LS	\$25,000	\$ 25,000
10	Aquionic Inline UV Disinfection System	1	LS	\$210,000	\$ 210,000
9	Mechanical: This would include installation of the UV equipment, all the ancillary equipment not provided in the equipment scope of supply, gates, process piping, utilities service connections, automatically control weir gates (at 20% of Equipment).	1	LS	20%	\$ 42,000
11	Electrical: Installation of all electrical and instrumentation components and programing (at 25% of mechanical).	1	LS	25%	\$ 52,500
12	Connect to Existing Domestic System	4	EA	\$ 10,000.00	\$ 40,000

Subtotal: \$ 1,394,306

Construction Subtotal: \$ 1,477,306

Construction Contingencies (25%): \$ 369,326

Construction Total: \$ 1,846,632

Preliminary Engineering & Environmental Documentation (8%): \$ 147,731

Plans, Specifications, and Estimates (10%): \$ 184,663

Administration, Construction Management, Testing & Inspection (15%): \$ 276,995

Soft Cost Total: \$ 609,389

Rounded Project Total: \$ 2,460,000

Table 8
Alternative 2 – SAWCo WTP Initial Capital Cost

No.	Description	Quantity	Unit	Unit Cost	Amount
General					
1	Mobilization/Demobilization, Bonds, Etc.	1	LS	5%	\$ 71,000
2	SWPPP, Best Management Practice	1	LS	\$10,000	\$ 10,000
3	Clearing and Grubbing	1	LS	\$5,000	\$ 5,000
Subtotal:					\$ 86,000
Site Demolition					
4	Remove and Disposal of Various Items	1	LS	\$5,000	\$ 5,000
Subtotal:					\$ 5,000
Site Improvements					
5	Construct Retaining Wall Extension Including Wrought Iron Fence	48	CY	\$1,200	\$ 57,777.78
6	Earthwork: This would include grading of area for the new retaining wall extension including fill.	600	CY	\$15	\$ 9,000.00
7	Construct 3" Asphalt Concrete Paving with 4" of CAB: This will be for the new extended area due to the retaining wall extension.	2,400	SF	\$8	\$ 19,200.00
8	Napier-Reid Pressure Filtration System	1	LS	\$670,000	\$ 670,000
7	Mechanical: This would include unloading & installation filters, automatically control weir gates, all the ancillary equipment not provided in the equipment scope of supply, process piping and connection of backwash, drain, overflow, influent, effluent; field welding, field assembly, ladder and platforms for filters, filling the tank, manufacturer support during installation, testing and operation of filters, weir gates, inspection and final equipment adjustment, gates etc. (at % of Equipment).	1	LS	25%	\$ 168,000
8	Electrical & Instrumentation: Installation of all electrical and instrumentation components, NTU meters, installation of control panels and integration into one system, integration of weir gates control, programming and connection to SCADA (at % of mechanical).	1	LS	20%	\$ 134,000
9	In Line Coagulation injection system	1	LS	\$25,000	\$ 25,000
10	Trojan UV Disinfection Channel System	1	LS	\$140,000	\$ 140,000
9	Mechanical: This would include installation of the UV equipment, all the ancillary equipment not provided in the equipment scope of supply, gates, process piping, utilities service connections, automatically control weir gates (at 30% of Equipment).	1	LS	30%	\$ 42,000
10	Structural: Work includes: earthwork, shoring, concrete structural, concrete pad for electrical equipment, stairs, hand rail, etc. (50% of equipment cost)	1	LS	50%	\$ 70,000
11	Electrical: Installation of all electrical and instrumentation components and programming (at 25% of mechanical).	1	LS	25%	\$ 35,000
12	Connect to Existing Domestic System	4	EA	\$ 10,000.00	\$ 40,000
Subtotal:					\$ 1,409,978
Construction Subtotal:					\$ 1,500,978
Construction Contingencies (25%):					\$ 375,244
Construction Total:					\$ 1,876,222
Preliminary Engineering & Environmental Documentation (8%):					\$ 150,098
Plans, Specifications, and Estimates (10%):					\$ 187,622
Administration, Construction Management, Testing & Inspection (15%):					\$ 281,433
Soft Cost Total:					\$ 619,153
Rounded Project Total:					\$ 2,500,000

9. Operation and Maintenance Costs Analysis

A preliminary operation and maintenance (O&M) analysis was prepared for the preferred Alternative 1, which consists of the Napier-Reid Pressure Filtration System and the Aquionics Proline PQ IL UV Disinfection System. TKE evaluated the 20-year life cycle cost, as well as the treatment cost per acre foot, assuming that the proposed WTP would operate about 5-months out of the year based on the historical flow data.

For the proposed WTP the major maintenance costs would come from the replacement of the media filter bed in the filtration system and the replacement of the UV bulbs in the disinfection system. The Napier-Reid Pressure Filtration System would require the filter media to be replaced every 10-years and would roughly cost around \$22,500 to replace all media layers for both filtration tanks. In addition, the Aquionics UV Disinfection System would require that the UV bulbs be replaced approximately every 12,000 hours of run time or about every 3-years. These two maintenance costs were included as part of the O&M cost tables that can be found in **Appendix B**. A summary of the O&M cost tables costs can be seen in **Table 9** below.

Table 9
WTP O&M Cost Summary

	Operating at 1 MGD with Additional Labor	Operating at Average Monthly Flow with Additional Labor	Operating at 1 MGD No Additional Labor	Operating at Average Monthly Flow No Additional Labor
Total Flow for 5 Months (MG)	153	100	153	100
Estimated Initial Capital Cost	\$2,460,000	\$2,460,000	\$2,460,000	\$2,460,000
Estimated Year 1 O&M Cost	\$139,343	\$122,765	\$47,543	\$30,965
Estimated 20-Year O&M Total Cost	\$3,825,205	\$3,379,748	\$1,358,504	\$913,048
Total Life Cycle Cost Over 20-Years	\$6,285,205	\$5,839,748	\$3,818,504	\$3,373,048
Annualized Life Cycle Cost	\$439,286	\$417,013	\$315,951	\$293,678
Annual Cost (\$/Acre Foot)	\$936	\$1,364	\$673	\$960

Table 9 summarizes and compares the O&M costs for the proposed WTP when operating at full capacity versus operating at the average monthly flow capacity based on historical flow data. The costs were annualized over a 20-year life cycle and broken down to show cost to treat the surface water from San Antonio Creek per acre-foot. In addition, the table identifies the cost to operate both with and without a new plant operator. It is assumed SAWCo would not be required to hire a new full-time employee just to operate the proposed WTP; rather, the O&M can be completed by existing operations staff that currently supervise, manage, and operate multiple SAWCo facilities. Based on this assumption, the cost to provide potable water from the San Antonio Creek runoff is between \$936 per acre-foot and \$960 per acre-foot depending on annual flow rate variations.

10. Conclusion

From TKE's analysis, the preferred alternative for SAWCo's potential surface water treatment plant would be Alternative 1 which consists of the Napier-Reid Pressure

Filtration System and the Aquionics, Inc. Proline PQ IL UV Disinfection System. The Napier-Reid Pressure Filtration System provides the required filtration to properly treat the San Antonio Creek surface water in a simple, compact, and cost-effective system. For water disinfection, a UV disinfection system would be a better option than traditional chlorination due to the compact footprint and does not require a specific contact time and special handling of dangerous chemicals. The Aquionics, Inc. Proline PQ IL UV Disinfection System provides the smallest footprint at a reasonable cost when the initial capital costs are compared. Overall, this alternative delivers the smallest overall required footprint that will work within the existing Forebay Facility with minimal site modification as well as provides the lowest initial capital cost out of all potential options evaluated in this budgetary study.

Appendix A
Preliminary Site Layout Exhibits

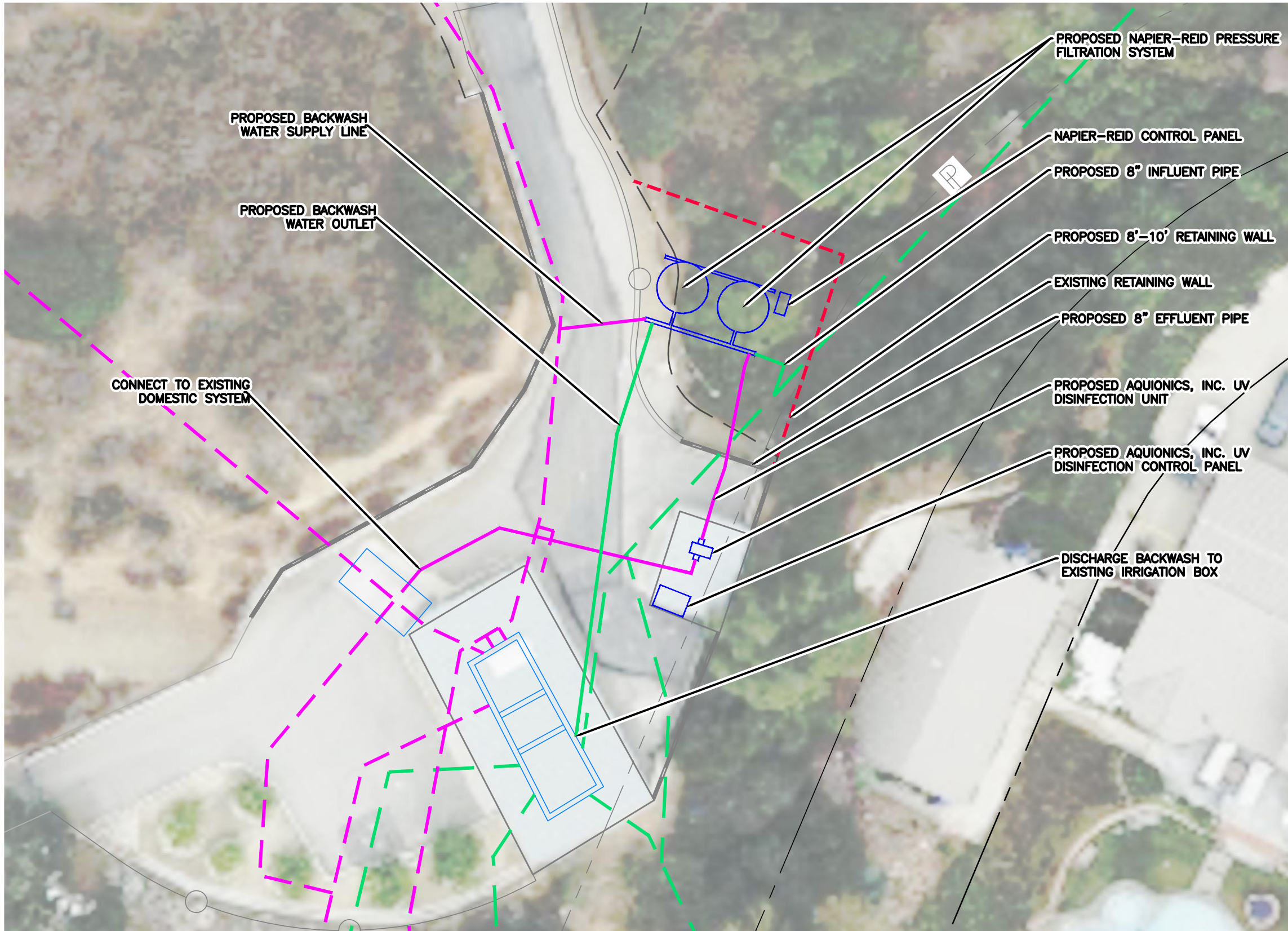

- EXISTING IRRIGATION MAIN
- EXISTING DOMESTIC MAIN
- PROPOSED IRRIGATION MAIN
- PROPOSED DOMESTIC MAIN
- - - PROPOSED 8'-10' RETAINING WALL

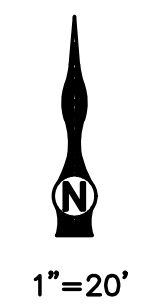

S:\CADD\112-20 Budgetary Study 1.0 MGD Treatment\Exhibits\Site Layout Exhibit Alternative 1.dwg

	TKE ENGINEERING, INC. 2305 CHICAGO AVENUE RIVERSIDE, CA 92507 (951) 680-0440 FAX: (951) 680-0490	SAN ANTONIO WATER CO. PRELIMINARY SITE LAYOUT EXHIBIT 1 - ALTERNATIVE 1

S:\GADD\112-20 Budgetary Study 1.0 MGD Treatment\Exhibits\Site Layout Exhibit Alternative 2.dwg

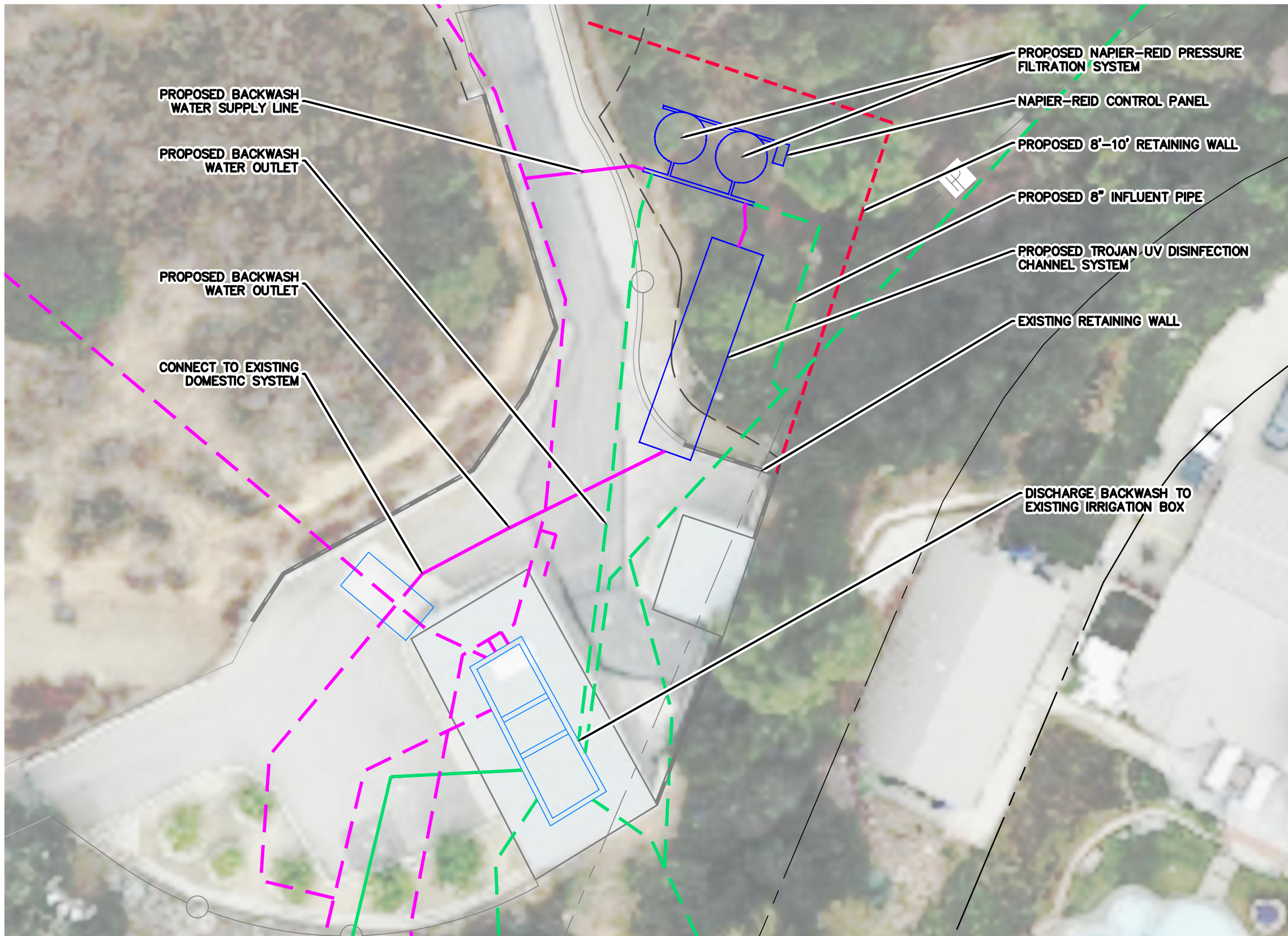

- - - EXISTING IRRIGATION MAIN
- - - EXISTING DOMESTIC MAIN
- PROPOSED IRRIGATION MAIN
- PROPOSED DOMESTIC MAIN
- - - PROPOSED 8'-10' RETAINING WALL



	TKE ENGINEERING, INC. 2305 CHICAGO AVENUE RIVERSIDE, CA 92507 (951) 680-0440 FAX: (951) 680-0490	SAN ANTONIO WATER CO. PRELIMINARY SITE LAYOUT EXHIBIT 2 - ALTERNATIVE 2

Appendix B
Preliminary O&M Cost Tables

San Antonio Water Company
San Antonio Creek 1 MGD Surface Water Treatment Plant
Operation and Maintenance Cost Estimate
Alternative 1
Operating at the Full 1 MGD Capacity

	Jan	Feb	Mar	Apr	May	Jun	Jul	Aug	Sep	Oct	Nov	Dec
Number of Days	31	28	31	30	31	30	31	31	30	31	30	31
Average Daily Flow (MGD)								1	1	1	1	1
Average Flow (MG)								31	30	31	30	31

Power Consumption	kWh	Jan	Feb	Mar	Apr	May	Jun	Jul	Aug	Sep	Oct	Nov	Dec
Napier-Reid Pressure Filtration System Power Consumption (kWh)	20	0	0	0	0	0	0	0	620	600	620	600	620
Aquanics UV Proline PQ IL	1248	0	0	0	0	0	0	0	38,688.00	37,440.00	38,688.00	37,440.00	38,688.00

Coagulant Consumption	gpd	Jan	Feb	Mar	Apr	May	Jun	Jul	Aug	Sep	Oct	Nov	Dec
FeCl ₃	16.5	0	0	0	0	0	0	0	511.5	495	511.5	495	511.5

Labor	Hours	Jan	Feb	Mar	Apr	May	Jun	Jul	Aug	Sep	Oct	Nov	Dec
Operator 1	8								248	240	248	240	248

Material	Frequency	Total Cost
Replace Media Filter	Every 10-Years	\$ 22,500
Replace UV Bulbs	Every 3-years	\$ 6,000

Year	Annual Cost
1	\$ 139,343.22
2	\$ 143,523.52
3	\$ 147,829.22
4	\$ 158,264.10
5	\$ 156,832.02
6	\$ 161,536.98
7	\$ 172,383.09
8	\$ 171,374.58
9	\$ 176,515.82
10	\$ 210,311.30
11	\$ 187,265.64
12	\$ 192,883.60
13	\$ 204,670.11
14	\$ 204,630.22
15	\$ 210,769.12
16	\$ 223,092.20
17	\$ 223,604.96
18	\$ 230,313.11
19	\$ 243,222.50
20	\$ 266,839.18
Total:	\$ 3,825,204.50

Cost (\$/kWh)	Total kWh	Total Cost
\$ 0.18	3,060	\$ 550.80
\$ 0.18	190,944	\$ 34,369.92
\$ 0.18	194,004	\$ 34,920.72

\$/gal	Total gal	Total Cost
\$ 5.00	2,524.50	\$ 12,622.50
		\$ 12,622.50

\$/HR	Total Hours	Total Cost
\$ 75.00	1,224	\$ 91,800.00
		\$ 91,800.00

Estimated Year One O&M Cost for 1MGD WTP: \$ 139,343.22

Notes:

- 1.) It is assumed the proposed plant would be operated 5 months out of the year based on the historical flow data
- 2.) The annual costs are calculated using a compound factor of 3% each year.
- 3.) Capital cost is based on Alternative 1 Preliminary Construction Cost.
- 4.) Pressure Filtration media need to be replace every 10 years. Cost to replace media is included in annual cost for year 10 and year 20

Estimated 20-Year O&M Cost:	\$ 3,825,204.50
Estimated Initial Capital Costs:	\$ 2,460,000.00
Life Cycle Cost (Over 20 year period):	\$ 6,285,204.50
Annualized Life Cycle Cost:	\$ 439,286.19
Annual Flow(MG)	153
Annual Cost (\$/Gal)	\$ 0.0029
Annual Cost (\$/AF)	\$ 935.53

San Antonio Water Company
San Antonio Creek 1 MGD Surface Water Treatment Plant
Operation and Maintenance Cost Estimate
Alternative 1
Operating to Treat the Average Monthly Flow

	Jan	Feb	Mar	Apr	May	Jun	Jul	Aug	Sep	Oct	Nov	Dec
Number of Days	31	28	31	30	31	30	31	31	30	31	30	31
Average Daily Flow (MGD)								0.7	0.6	0.55	0.5	0.9
Average Flow (MG)								21.7	18	17.05	15	27.9

Power Consumption	kWh	Jan	Feb	Mar	Apr	May	Jun	Jul	Aug	Sep	Oct	Nov	Dec
Napier-Reid Pressure Filtration System Power Consumption (kWh)	20	0	0	0	0	0	0	0	434	360	341	300	558
Aquanics UV Proline PQ IL	1248	0	0	0	0	0	0	0	27,081.60	22,464.00	21,278.40	18,720.00	34,819.20

Coagulant Consumption	gpd	Jan	Feb	Mar	Apr	May	Jun	Jul	Aug	Sep	Oct	Nov	Dec
FeCl ₃	16.5	0	0	0	0	0	0	0	358.05	297	281.325	247.5	460.35

Labor	Hours	Jan	Feb	Mar	Apr	May	Jun	Jul	Aug	Sep	Oct	Nov	Dec
Operator 1	8								248	240	248	240	248

Material	Frequency	Total Cost
Replace Media Filter	Every 10-Years	\$ 22,500
Replace UV Bulbs	Every 3-years	\$ 6,000

Year	Annual Cost
1	\$ 122,765.24
2	\$ 126,448.20
3	\$ 130,241.64
4	\$ 140,148.89
5	\$ 138,173.36
6	\$ 142,318.56
7	\$ 152,588.12
8	\$ 150,985.76
9	\$ 155,515.33
10	\$ 188,680.79
11	\$ 164,986.22
12	\$ 169,935.80
13	\$ 181,033.88
14	\$ 180,284.90
15	\$ 185,693.44
16	\$ 197,264.25
17	\$ 197,002.17
18	\$ 202,912.24
19	\$ 214,999.61
20	\$ 237,769.59
Total:	\$ 3,379,748.00

Cost (\$/kWh)	Total kWh	Total Cost
99.65 MG		
\$ 0.18	1,993	\$ 358.74
\$ 0.18	124,363	\$ 22,385.38
\$ 0.18	126,356	\$ 22,744.12
\$/gal	Total gal	Total Cost
\$ 5.00	1,644.23	\$ 8,221.13
		\$ 8,221.13
\$/HR	Total Hours	Total Cost
\$ 75.00	1,224	\$ 91,800.00
		\$ 91,800.00

Estimated Year One O&M Cost for 1MGD WTP: \$ 122,765.24

Notes:

- 1.) It is assumed the proposed plant would be operated 4 months out of the year based on the historical flow data
- 2.) The annual costs are calculated using a compound factor of 3% each year.
- 3.) Capital cost is based on Alternative 1 Preliminary Construction Cost.
- 4.) Pressure Filtration media need to be replace every 10 years. Cost to replace media is included in annual cost for year 10 and year 20

Estimated 20-Year O&M Cost:	\$ 3,379,748.00
Estimated Initial Capital Costs:	\$ 2,460,000.00
Life Cycle Cost (Over 20 year period):	\$ 5,839,748.00
Annualized Life Cycle Cost:	\$ 417,013.36
Annual Flow(MG)	100
Annual Cost (\$/Gal)	\$ 0.0042
Annual Cost (\$/AF)	\$ 1,363.56

San Antonio Water Company
San Antonio Creek 1 MGD Surface Water Treatment Plant
Operation and Maintenance Cost Estimate
Alternative 1
Operating at the Full 1 MGD Capacity (No Additional FTE)

	Jan	Feb	Mar	Apr	May	Jun	Jul	Aug	Sep	Oct	Nov	Dec
Number of Days	31	28	31	30	31	30	31	31	30	31	30	31
Average Daily Flow (MGD)								1	1	1	1	1
Average Flow (MG)								31	30	31	30	31

Power Consumption		kWh											
Napier-Reid Pressure Filtration System Power Consumption (kWh)	20	0	0	0	0	0	0	0	620	600	620	600	620
Aquanics UV Proline PQ IL	1248	0	0	0	0	0	0	0	38,688.00	37,440.00	38,688.00	37,440.00	38,688.00

Coagulant Consumption		gpd											
FeCl ₃	16.5	0	0	0	0	0	0	0	511.5	495	511.5	495	511.5

Labor		Hours											
Operator 1	0								0	0	0	0	0

Material	Frequency	Total Cost
Replace Media Filter	Every 10-Years	\$ 22,500
Replace UV Bulbs	Every 3-years	\$ 6,000

Total			Year	Annual Cost
153 MG			1	\$ 47,543.22
			2	\$ 48,969.52
			3	\$ 50,438.60
			4	\$ 57,951.76
			5	\$ 53,510.31
			6	\$ 55,115.62
			7	\$ 62,769.09
			8	\$ 58,472.16
			9	\$ 60,226.33
			10	\$ 90,533.12
			11	\$ 63,894.11
			12	\$ 65,810.94
			13	\$ 73,785.26
			14	\$ 69,818.82
			15	\$ 71,913.39
			16	\$ 80,070.79
			17	\$ 76,292.91
			18	\$ 78,581.70
			19	\$ 86,939.15
			20	\$ 105,867.32
			Total:	\$ 1,358,504.13

Cost (\$/kWh)	Total kWh	Total Cost
\$ 0.18	3,060	\$ 550.80
\$ 0.18	190,944	\$ 34,369.92
\$ 0.18	194,004	\$ 34,920.72

\$/gal	Total gal	Total Cost
\$ 5.00	2,524.50	\$ 12,622.50
		\$ 12,622.50

\$/HR	Total Hours	Total Cost
\$ 75.00	-	\$ -
		\$ -

Estimated Year One O&M Cost for 1MGD WTP: \$ 47,543.22

Notes:

- 1.) It is assumed the proposed plant would be operated 4 months out of the year based on the historical flow data
- 2.) The annual costs are calculated using a compound factor of 3% each year.
- 3.) Capital cost is based on Alternative 1 Preliminary Construction Cost.
- 4.) Pressure Filtration media need to be replaced every 10 years. Cost to replace media is included in annual cost for year 10 and year 20
- 5.) Assuming SAWCo would not hire a new full time employee to oversee this WTP

Estimated 20-Year O&M Cost:	\$ 1,358,504.13
Estimated Initial Capital Costs:	\$ 2,460,000.00
Life Cycle Cost (Over 20 year period):	\$ 3,818,504.13
Annualized Life Cycle Cost:	\$ 315,951.17
Annual Flow(MG)	153
Annual Cost (\$/Gal)	\$ 0.0021
Annual Cost (\$/AF)	\$ 672.87

San Antonio Water Company
San Antonio Creek 1 MGD Surface Water Treatment Plant
Operation and Maintenance Cost Estimate
Alternative 1
Operating to Treat the Average Monthly Flow (No Additional FTE)

	Jan	Feb	Mar	Apr	May	Jun	Jul	Aug	Sep	Oct	Nov	Dec
Number of Days	31	28	31	30	31	30	31	31	30	31	30	31
Average Daily Flow (MGD)								0.7	0.6	0.55	0.5	0.9
Average Flow (MG)								21.7	18	17.05	15	27.9

Power Consumption	kWh	Jan	Feb	Mar	Apr	May	Jun	Jul	Aug	Sep	Oct	Nov	Dec
Napier-Reid Pressure Filtration System Power Consumption (kWh)	20	0	0	0	0	0	0	0	434	360	341	300	558
Aquanics UV Proline PQ IL	1248	0	0	0	0	0	0	0	27,081.60	22,464.00	21,278.40	18,720.00	34,819.20

Coagulant Consumption	gpd	Jan	Feb	Mar	Apr	May	Jun	Jul	Aug	Sep	Oct	Nov	Dec
FeCl ₃	16.5	0	0	0	0	0	0	0	358.05	297	281.325	247.5	460.35

Labor	Hours	Jan	Feb	Mar	Apr	May	Jun	Jul	Aug	Sep	Oct	Nov	Dec
Operator 1	0								0	0	0	0	0

Material	Frequency	Total Cost
Replace Media Filter	Every 10-Years	\$ 22,500
Replace UV Bulbs	Every 3-years	\$ 6,000

Year	Annual Cost
1	\$ 30,965.24
2	\$ 31,894.20
3	\$ 32,851.02
4	\$ 39,836.55
5	\$ 34,851.65
6	\$ 35,897.20
7	\$ 42,974.12
8	\$ 38,083.34
9	\$ 39,225.84
10	\$ 68,902.62
11	\$ 41,614.69
12	\$ 42,863.14
13	\$ 50,149.03
14	\$ 45,473.50
15	\$ 46,837.71
16	\$ 54,242.84
17	\$ 49,690.12
18	\$ 51,180.83
19	\$ 58,716.25
20	\$ 76,797.74
Total:	\$ 913,047.62

Cost (\$/kWh)	Total kWh	Total Cost
99.65 MG		
\$ 0.18	1,993	\$ 358.74
\$ 0.18	124,363	\$ 22,385.38
\$ 0.18	126,356	\$ 22,744.12

\$/gal	Total gal	Total Cost
\$ 5.00	1,644.23	\$ 8,221.13
		\$ 8,221.13

\$/HR	Total Hours	Total Cost
\$ 75.00	-	\$ -
		\$ -

Estimated Year One O&M Cost for 1MGD WTP: \$ 30,965.24

Notes:

- 1.) It is assumed the proposed plant would be operated 4 months out of the year based on the historical flow data
- 2.) The annual costs are calculated using a compound factor of 3% each year.
- 3.) Capital cost is based on Alternative 1 Preliminary Construction Cost.
- 4.) Pressure Filtration media need to be replace every 10 years. Cost to replace media is included in annual cost for year 10 and year 20
- 5.) Assuming SAWCo would not hire a new full time employee to oversee this WTP

Estimated 20-Year O&M Cost:	\$ 913,047.62
Estimated Initial Capital Costs:	\$ 2,460,000.00
Life Cycle Cost (Over 20 year period):	\$ 3,373,047.62
Annualized Life Cycle Cost:	\$ 293,678.34
Annual Flow(MG)	100
Annual Cost (\$/Gal)	\$ 0.0029
Annual Cost (\$/AF)	\$ 960.28

Appendix C
Manufacture Data



Upland WTP

California

Engineer
TKE Engineering

Contact
Adrian Williams
awilliams@westtech-inc.com

Representative
Tom Roberso
MISCOWater
Foothill Ranch, California
(949) 458-5555
troberson@miscowater.com

Gerry Baker
gbaker@westtech-inc.com



Proposal Number: 2230276
Friday, June 24, 2022



Table of Contents

Technical Proposal

Item A – Two (2) Trident® Units, Model TR-210A

Clarifications and Exceptions

Commercial Proposal

Bidder's Contact Information

Pricing

Payment Terms

Schedule

Freight

Warranty

Terms & Conditions

Technical Proposal

Item A – Two (2) Trident® Package Treatment Units, Model TR-210A

Design Criteria	
Application	Treatment for Drinking Water
Trident System Design Flow	700 gpm
Number of Units	2; (350 gpm per unit)
Project Flow	700 gpm (max)
Adsorption Clarifier® Area	35 ft ² per unit
Adsorption Clarifier Loading Rate	10 gpm/ft ² (@ design flow)
Adsorption Clarifier Water Flush Rate	350 gpm
Adsorption Clarifier Air Flush Rate	360 scfm (10 scfm/ft ²)
Filter Area	70 ft ² per unit
Filter Loading Rate	5 gpm/ft ² (@ design flow)
Backwash Method	Air & Water
Low-Rate Backwash Water Loading Rate	5.0 gpm/ft ²
Low-Rate Backwash Water Flow Rate	350 gpm
High-Rate Backwash Water Loading Rate*	15 gpm/ft ²
High-Rate Backwash Water Flow Rate*	1050 gpm
Airwash Loading Rate	5 scfm/ft ²
Airwash Flow Rate	360 scfm
Backwash Water Source	External backwash supply
Backwash Control	High and low using three valve loop configuration

* The design high-rate backwash listed is based on a temperature of 25 °C. The actual backwash water rate must be adjusted 2% up or down for each degree Celsius difference above or below from design temperature; i.e., above 25 °C increase by 2%, below 25 °C decrease by 2%.

Features and Benefits

The Trident® is a pre-engineered system consisting of a pretreatment and filtration system contained in a single shippable tank. The internal components and ancillaries shall be shipped loose for installation by the contractor. The Trident system combines a variety of chemical treatment solutions. The patented MMAC Adsorption Clarifier® system and Mixed Media Filter deliver excellent predictable finished water quality. The system also includes the MULTIBLOCK® direct retention air/water backwash underdrain system. An optional scalloped underdrain allows for additional depth of filter or layer of activated carbon without an increase in tank height. Each system includes the Aquaritol® PLC program for continuous effluent quality control.

- Treat water with up to 75 NTU or up to 35 color units.
- Treat water with combined total NTU and color of 75.
- Capable of 2 log removal of Crypto and Giardia size particles.
- Up to 3 log removal demonstrated by pilot studies.
- Proprietary design with over 700 installations.
- The clarifier reduces turbidity 75–95%, causing settling to be insignificant.
- The Trident system reduces coagulant usage 5–10% and filter aid usage as much as 60%.

- Installation costs are less than that of conventional systems.
- The footprint is up to 60% smaller than conventional plants.

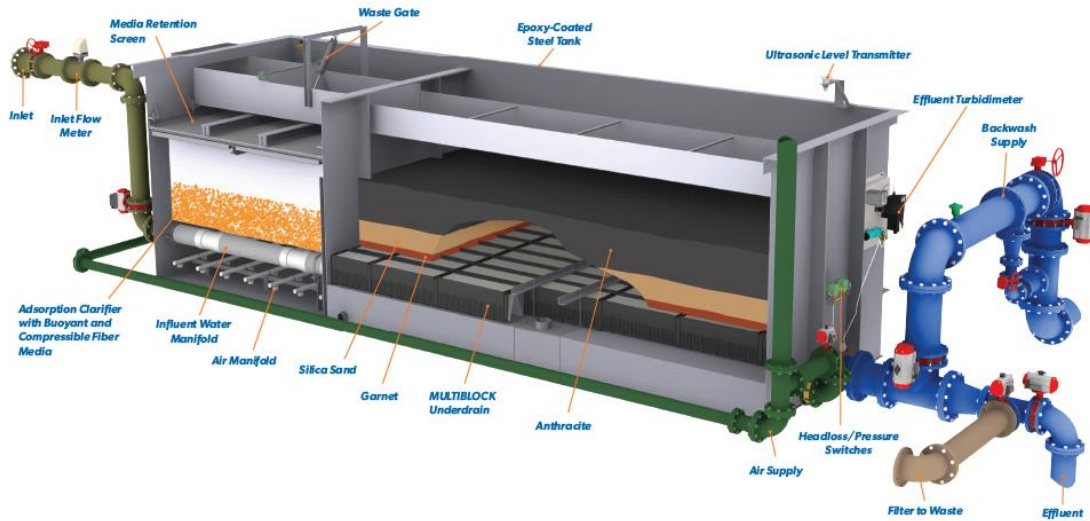

Trident® system depicted. May not entirely reflect unit quoted.

Tankage Scope of Supply

Item	Size
Tank Material	Carbon Steel
Tank Dimensions	14 ft 6 in long x 8 ft 11 in wide x 8 ft 5 in tall
Weights (per unit, approximate)	10,250 lbs (Shipping), 70,000 lbs (Operating)

Note

- Tank is shipped without internals. Internal components and ancillaries listed below are shipped loose for installation by others.

Tank Connections

Item	Size
Influent	6 in
Filter Effluent/Backwash Supply	8 in
Waste/Overflow	10 in
Adsorption Clarifier Air	3 in
Filter Air	4 in

Tank Coatings

Item	Location
Tank Interior	Prepared per paint manufacturer recommendations, painted with one coat of Tnemec #N140-1255 Pota-Pox primer and one coat of Tnemec #N140-15BL Pota-Pox finish paint.
Tank Exterior	Prepared per paint manufacturer recommendations, painted with one coat of Tnemec #N140-1255 Pota-Pox. Field finish to be applied by others.
Tank Bottom	Tank is unpainted on bottom exterior surface and designed for installation on coal tar or asphaltic type base mastic compound applied to concrete base pad by others.

Adsorption Clarifier Scope of Supply

Feature	Quantity	Notes
Adsorption Clarifier Media	140 ft ³ /unit	Media depth is 4 ft. Adsorption Clarifier media is 50% beads and 50% fiber balls. Beads are 50/50 R&S. All media is NSF Std. 61 approved.
Clarifier Media Retention	35 ft ² /unit	Stainless steel screen mesh under aluminum grating
Splash Guards	1 set/unit	For placement around the top tank perimeter of AC section on three sides; with support angles & attachment hardware
Collection Trough	1/unit	Rectangular trough with waste gate running length of AC section
Inlet Distribution	1 Lot/unit	PVC header-lateral pipe system with supports
Air Distribution	1 Lot/unit	PVC header-lateral pipe system with supports
Lower media support grating	35 ft ² /unit	Aluminum grating at the bottom

Note

- Components and media are shipped loose for installation by others.

Filter Scope of Supply

Feature	Quantity	Notes
MULTIBLOCK [®] Underdrain	70 ft ² /unit	Dual lateral blocks, 11" wide x 12" high x 36" long designed to interlock with each other to form the overall lateral length. The underdrain system shall include a factory installed media-retaining Laser Shield™ plate constructed of 304 stainless steel.
Washtrough	1/unit	Rectangular trough running length of filter section
Air/Water Distribution	1 Lot/unit	304 stainless steel plenum with air and water connections (factory installed)

Note

- Concrete fill of 1.9 yd³/unit is required to be placed in the bottom of filter section for support of MULTIBLOCK laterals. Concrete fill and grout not by WesTech.
- All required hardware is supplied by WesTech for assembly of the tank internals at the jobsite by the contractor.
- Components unless otherwise noted are shipped loose for installation by others.

Media Scope of Supply

Type	Quantity	Layer Depth	Effective Size	Uniformity Coefficient	Packaging
Anthracite	107 ft ³ /unit	18 in	1.0-1.1 mm	≤1.7	1-ft ³ bags on pallets
Silica Sand	56 ft ³ /unit	9 in	0.35-0.45 mm	≤1.4	1-ft ³ bags on pallets
Garnet	19 ft ³ /unit	3 in	0.2-0.32 mm	≤1.7	50# bags on pallets

Note

- Media quantities include sufficient volume for skimming.
- Media is shipped loose for installation by others.

Air Scour Blower Scope of Supply

Quantity	Volume	Pressure	Type	Motor
2	180 scfm (each)	4.1 PSG	Regenerative	10 hp, 230/460 V, 60 Hz, 3 ph, TEFC

Blower Accessories

- Air intake filter with dirty filter indicator
- Pressure safety relief valve
- Check valve
- Blower pressure indicator

Note

- Pressure gauge and switch to be placed in main air supply line for installation by others.
- Components are shipped loose for installation by others.
- Motor starters (if required), electrical wiring, conduit, and connection of electrical wiring to terminals within WesTech's control panels is not provided by WesTech and is to be furnished and installed by others.

Valves Scope of Supply

Item	Size	Quantity	Type	Operator Type
Influent Valve	6 in	1/unit	Butterfly, Wafer	Electro-pneumatic, Modulating
Backwash Inlet Valve	8 in	1/unit	Butterfly, Wafer	Pneumatic, Open/Close
Backwash High-Rate Valve	8 in	1/system	Butterfly, Wafer	Pneumatic, Open/Close
Effluent	6 in	1/unit	Butterfly, Wafer	Electro-pneumatic, Modulating
Filter to Waste	6 in	1/unit	Butterfly, Wafer	Electro-pneumatic, Modulating
AC Air Scour	3 in	1/unit	Butterfly, Wafer	Pneumatic, Open/Close
Filter Air Scour	4 in	1/unit	Butterfly, Wafer	Pneumatic, Open/Close
Waste Gate	N/A	1/unit	Linear Cylinder	Pneumatic, Open/Close
Backwash Low-Rate Set	3 in	1/system	Butterfly, Wafer	Manual, Handwheel
Backwash High-Rate Set	8 in	1/system	Butterfly, Wafer	Manual, Handwheel
Influent Isolation	6 in	1/unit	Butterfly, Wafer	Manual, Handwheel
AC Air Check Valve	3 in	1/unit	Check	None
Filter Air Check Valve	4 in	1/unit	Check	None

Note

- All butterfly valves are **Bray** wafer style with cast iron body, nylon coated disc, EPDM seat and shaft seal. Automatic butterfly valves have double acting, weatherproof pneumatic cylinder actuators manufactured by **Bray**.

- Valves are shipped loose for installation by others.
- Electrical wiring, conduit, and connection of electrical wiring to terminals within WesTech’s control panels is not provided by WesTech and is to be furnished and installed by others.
- Pneumatic tubing from air compressor to valves is not provided by WesTech and is to be furnished and installed by others.

Trident Master Control Panel Scope of Supply

Feature	Description	Notes
Number of Panels	1	
Housing	NEMA 4/12	Wall mounted
PLC	Allen Bradley CompactLogix	Includes Aquaritrol program logic
OIT	Allen Bradley PanelView	10” color touchscreen interface
SCADA Interface		Communication protocol via Ethernet/IP

Note

- The panel is shipped loose for installation by others.
- Panel exterior electrical wiring, conduit, and connection of electrical wiring to terminals within WesTech’s control panels is not provided by WesTech and is to be furnished and installed by others.

Instrumentation Scope of Supply

Description	Quantity	Type	Signal	Notes
Inlet Meter	1/unit	Magnetic Flow	4–20 mA	Endress+Hauser
Filter Liquid Level Transmitter	1/unit	Radar	4–20 mA	Endress+Hauser w/ mounting bracket
Backwash Control Level Switches	2/unit	Float	On/Off	One low & one high
Clarifier Pressure Transmitter	1/unit	Transmitter assembly with digital display	4-20 mA	Rosemount
Filter Pressure Transmitter	1/unit	Transmitter assembly with digital display	4-20 mA	Rosemount
Air Scour Blower Pressure Switch	1/system	2 ½ in, 0–5 psi	Discrete	Ashcroft
Effluent Turbidimeter	1/unit	TU5300 sc	To SC4500	HACH with power & communication cables
Turbidimeter Controller	1	SC4500	4-20 mA	HACH, one unit is used for each pair (two) turbidimeters
Effluent Turbidity Sample Pump	1/unit	1/16 hp Centrifugal	N/A	115 V, 60 Hz, 1 ph
Calibration kit	1	NTU Standards	N/A	HACH

Note

- Components are shipped loose for installation at the jobsite by others.
- Electrical wiring, conduit, and connection of electrical wiring to terminals within WesTech’s control panels is not provided by WesTech and is to be furnished and installed by others.

Coagulant Feed Scope of Supply

Feature	Quantity	Notes
Tank	1	200-gallon HDPE with cover
Chemical Feed Pump	1	480 gpd positive displacement diaphragm type, electronic control by Aquaritrol® PLC program
Mixer	1	Tank mounted, direct drive ¼ hp, 115/230 V, 60 Hz, single phase motor with stainless steel shaft and dual propellers. Support is included
Analog to Digital Converter	1	4–20 mA output
Calibration Column	1	1000 mL with connection nipple
Corporation Stop and Nozzle	1	¾ in NPT-bronze with CPVC nozzle
Ball Valves	3	½ in NPT, PVC
Misc. Hardware	1 lot	

Note

- Coagulant feed components shipped loose for installation by others.
- Coagulant pump size based on one unit in service.

Filter Aid Polymer Feed Scope of Supply

Feature	Quantity	Notes
Tank	1	200-gallon HDPE with cover
Chemical Feed Pump	1/unit	108 gpd positive displacement diaphragm type, electronic control by Aquaritrol® PLC program
Mixer	1	Tank mounted, direct drive ¼ hp, 115/230 V, 60 Hz, single phase motor with stainless steel shaft and dual propellers. Support is included
Chemical Disperser	1	Funnel for mixing tank
Calibration Column	1	1000 mL with connection nipple
Corporation Stop and Nozzle	1	¾ in NPT-bronze with CPVC nozzle
Ball Valves	4	½ in NPT, PVC
Misc. Hardware	1 lot	

Note

- Polymer feed components shipped loose for installation by others.

WesTech Trips to the Site

Total Trips	Total Days	Includes
4	15	Installation inspection of major Trident components, observation of filter media installation, startup, and instruction of plant personnel

Note: Any Item Not Listed Above to Be Furnished by Others.

Clarifications and Exceptions

General Clarifications

Terms & Conditions: This proposal, including all terms and conditions contained herein, shall become part of any resulting contract or purchase order. Changes to any terms and conditions, including but not limited to submittal and shipment days, payment terms, and escalation clause shall be negotiated at order placement, otherwise the proposal terms and conditions contained herein shall apply.

Paint: If your equipment has paint included in the price, please take note to the following. Primer paints are designed to provide only a minimal protection from the time of application (usually for a period not to exceed 30 days). Therefore, it is imperative that the finish coat be applied within 30 days of shipment on all shop primed surfaces. Without the protection of the final coatings, primer degradation may occur after this period, which in turn may require renewed surface preparation and coating. If it is impractical or impossible to coat primed surfaces within the suggested time frame, WesTech strongly recommends the supply of bare metal, with surface preparation and coating performed in the field. All field surface preparation, field paint, touch-up, and repair to shop painted surfaces are not by WesTech.

Escalation: If between the proposal date and actual procurement and through no fault of the Seller, the relevant cost of labor, material, freight, tariffs, and other Seller costs combined relating to the contract, increase by greater than 2.5% of the overall contract price, then the contract price shall be subject to escalation and increased. Such increase shall be verified by documentation and the amount of contract price escalation shall be calculated as either the actual increased cost to the Seller or, if agreed by the Parties, the equivalent increase of a relevant industry recognized third-party index, and in both cases without any additional profit or margin being added.

USA Tariffs and Current Trade Laws: All prices are based on current USA and North America tariffs and trade laws/agreements at time of bid. Any changes in costs due to USA Tariffs and trade laws/agreements will be passed through to the purchaser at cost.

Trident Clarifications

- The Trident is a pre-engineered system consisting of a pretreatment and filtration system contained in a single shippable tank. The tank is shipped without internals. All internal components and ancillaries shall be shipped loose for installation by others.
- The filter is periodically backwashed (using treated water). The Adsorption Clarifier is normally washed (using influent water) one or more times between filter backwashes. The waste holding system should be sized to handle a total of two complete flush/wash volumes from each compartment.
- The influent pumping system should provide a range of 20–30 feet head at tank inlet connection. The high-rate water only backwash of the filter shall be 15–18 gpm/ft² with an available head of 13 feet at the tank connection.
- A 50 percent duty cycle is recommended for the compressed air system.
- Availability of equipment components specified may dictate substitutions of equal quality at the discretion of WesTech.
- All hardware is crated and shipped to the jobsite for assembly by the contractor.

Items not furnished by WesTech

- Unloading of equipment from delivering carrier, protected storage of equipment
- Installation, supervision of installation
- All underground and interconnecting piping, filter face piping and fittings, pipe supports, wall inserts or sleeves, Dresser or flexible couplings, hangers, valves (not specifically listed), pneumatic tubing from air compressor to filter batteries, air release piping and valves, sampling lines and sinks, small pressure water supply piping, field work of piping (ie: drilling and tapping for instrumentation) and flow meters
- Interconnection wiring and conduit
- Walkways, handrails, stairways and ladders
- Finish paint and intermediate field coats; cathodic protection systems
- All chemical feeders (not specifically listed), feed lines, start-up chemicals, chemicals, tanks (not specifically listed), labor and procedures for the disinfection of equipment, laboratory test equipment
- Structural design, supply and installation of concrete pads, foundations, rebar, anchors, concrete, grout, sealant, sumps and concrete fill for filter underdrains, clearwell
- Motor control center, motor starters, disconnects, electrical wiring and conduit, connection of electrical wiring to terminals within WesTech's control panels, telemetering equipment, level controls, turbidity monitoring equipment (not specifically listed), supports for controls
- SCADA System
- All pumps, air compressors, dryers, operating and start-up lubricants
- Any equipment or service not listed in this proposal

Exceptions

Not applicable

Commercial Proposal

Proposal Name: Upton WTP

Proposal Number: 2230276

Friday, June 24, 2022

1. Bidder's Contact Information

Company Name	WesTech Engineering, LLC
Primary Contact Name	Adrian Williams
Phone	(801) 265-1000
Email	awilliams@westech-inc.com
Address: Number/Street	3665 S West Temple
Address: City, State, Zip	Salt Lake City, UT 84115

2. Budget Pricing

Currency: USD

Scope of Supply

A	Two (2) Trident® TR-210A Units, Model TR-210A	\$655,000
	Taxes (sales, use, VAT, IVA, IGV, duties, import fees, etc.)	Not Included

Prices are valid for a period not to exceed 30 days from date of proposal.

Additional Field Service

Daily Rate (Applicable Only to Field Service Not Included in Scope)	\$1,200
---	---------

Pricing does not include field service unless noted in scope of supply, but is available at the daily rate plus expenses. The greater of a two week notice or visa procurement time is required prior to departure date. Our field service policy can be provided upon request for more details.

3. Payment Terms

Purchase Order Acceptance and Contract Execution	10%
Submittals Provided by WesTech	15%
Release for Fabrication	35%
Notification of Ready to Ship	40%

All payments are net 30 days. Partial shipments are allowed. An approved Letter of Credit is required if Incoterms CIF, CFR, DAP, CIP, or CPT are applicable. Payment is required in full for all other Incoterms prior to international shipment. Other terms per WesTech proforma invoice. Please note that the advising bank must be named as: Wells Fargo Bank, International Department, 9000 Flair Drive, 3rd Floor, El Monte, California 91731, USA.

4. Schedule

Submittals, after Purchase Order Acceptance and Contract Execution	10 to 12 weeks
Ready to Ship, after Receipt of Final Submittal Approval	22 to 24 weeks
Estimated Weeks to Ready to Ship	32 to 36 weeks*

*Customer submittal approval is typically required to proceed with equipment fabrication and is not accounted for in the schedule above. Project schedule will be extended to account for time associated with receipt of customer submittal approval.

5. Freight

Domestic	FOB Shipping Point - Full Freight Allowed to Jobsite (FSP-FFA)	
From	Final Destination	Number of Trucks or Containers
WesTech Shops	Upland, California	TBD

One-Year Warranty

WesTech is meeting a global need for clean water through technology treatment solutions. We are proud that the equipment and systems we design, build, maintain, and operate are making the world a better place and creating a more sustainable environment for future generations.

Equipment manufactured or sold by WesTech Engineering, LLC, once paid for in full, is backed by the following warranty:

Subject to the terms below, WesTech warrants all new equipment manufactured or sold by WesTech Engineering, LLC to be unencumbered and free from defects in material and workmanship, and WesTech will replace or repair, F.O.B. its factories or other location it chooses, any part or parts returned to WesTech which WesTech's examination and analysis determine have failed within the warranty period because of defects in material and workmanship. The warranty period is either, one calendar year immediately following start-up, or eighteen (18) months from when WesTech sent its ready-to-ship notification to the purchaser, whichever expires sooner. All repair or replacement parts qualifying under this warranty shall be free of charge. Purchaser will provide timely written notice to WesTech of any defects it believes should be repaired or replaced under this warranty. WesTech will reject as untimely any warranty defect claim that purchaser submits more than thirty (30) days after the possible warranty defect first occurred. Unless specifically stated otherwise, this warranty does not cover normal wear or consumables. This warranty is not transferable. This warranty shall be void and shall not apply where the equipment or any part thereof

- (a) has been dismantled, modified, repaired or connected to other equipment, outside of a WesTech factory, or without WesTech's written approval, or
- (b) has not been installed in complete adherence to all WesTech's or parts manufacturer's requirements, recommendations, and procedures, or
- (c) has been subject to misuse, abuse, neglect, or accident, or has not at all times been operated and maintained in strict compliance with all of WesTech's requirements and recommendations therefor, including, but not limited to, the relevant WesTech Operations & Maintenance Manual and any other of WesTech's specified guidelines & procedures, or
- (d) has been subject to force majeure events; use of chemicals not approved in writing by WesTech; electrical surges; overloading; significant power, water or feed supply fluctuations; or non-compliance with agreed feedwater or chemical volumes, specifications or procedures.

In any case where a part or component of equipment under this warranty is or may be faulty and the component or part is also covered under the warranty of a third party then the purchaser shall provide reasonable assistance to first pursue a claim under the third party warranty before making a claim under this warranty from WesTech. WesTech Engineering, LLC gives no warranty with respect to parts, accessories, or components purchased other than through WesTech. The warranties which apply to such items are those offered by the respective manufacturers.

This warranty is expressly given by WesTech and accepted by purchaser in lieu of all other warranties whether written, oral, express, implied, statutory or otherwise, including without limitation, warranties of merchantability and fitness for particular purpose. WesTech neither accepts nor authorizes any other

person to assume for it any other liability with respect to its equipment. WesTech shall not be liable for normal wear and tear, corrosion, or any contingent, incidental, or consequential damage or expense due to partial or complete inoperability of its equipment for any reason whatsoever. The purchaser's exclusive and only remedy for breach of this warranty shall be the repair and or replacement of the defective part or parts within a reasonable time of WesTech's accepting the validity of a warranty claim made by the purchaser.

Terms & Conditions

Terms and Conditions appearing in any order based on this proposal which are inconsistent herewith shall not be binding on WesTech Engineering, LLC. The sale and purchase of equipment described herein shall be governed exclusively by the foregoing proposal and the following provisions:

1. SPECIFICATIONS: WesTech Engineering, LLC is furnishing its standard equipment as outlined in the proposal and as will be covered by final approved drawings. The equipment may not be in strict compliance with the Engineer's/Owner's plans, specifications, or addenda as there may be deviations. The equipment will, however, meet the general intention of the mechanical specifications of these documents.

2. ITEMS INCLUDED: This proposal includes only the equipment specified herein and does not include erection, installation, accessories, nor associated materials such as controls, piping, etc., unless specifically listed.

3. PARTIES TO CONTRACT: WesTech Engineering, LLC is not a party to or bound by the terms of any contract between WesTech Engineering, LLC's customer and any other party. WesTech Engineering, LLC's undertakings are limited to those defined in the contract between WesTech Engineering, LLC and its direct customers.

4. PRICE AND DELIVERY: All selling prices quoted are subject to change without notice after 30 days from the date of this proposal unless specified otherwise. Unless otherwise stated, all prices are F.O.B. WesTech Engineering, LLC or its supplier's shipping points. All claims for damage, delay or shortage arising from such equipment shall be made by Purchaser directly against the carrier. When shipments are quoted F.O.B. job site or other designation, Purchaser shall inspect the equipment shipped, notifying WesTech Engineering, LLC of any damage or shortage within forty-eight hours of receipt, and failure to so notify WesTech Engineering, LLC shall constitute acceptance by Purchaser, relieving WesTech Engineering, LLC of any liability for shipping damages or shortages.

5. PAYMENTS: All invoices are net 30 days. Delinquencies are subject to a 1.5 percent service charge per month or the maximum permitted by law, whichever is less on all past due accounts. Pro rata payments are due as shipments are made. If shipments are delayed by the Purchaser, invoices shall be sent on the date when WesTech Engineering, LLC is prepared to make shipment and payment shall become due under standard invoicing terms. If the work to be performed hereunder is delayed by the Purchaser, payments shall be based on the purchase price and percentage of completion. Products held for the Purchaser shall be at the risk and expense of the Purchaser. Unless specifically stated otherwise, prices quoted are for equipment only. These terms are independent of and not contingent upon the time and manner in which the Purchaser receives payment from the owner.

6. PAYMENT TERMS: Credit is subject to acceptance by WesTech Engineering, LLC's Credit Department. If the financial condition of the Purchaser at any time is such as to give WesTech Engineering, LLC, in its judgment, doubt concerning the Purchaser's ability to pay, WesTech Engineering, LLC may require full or partial payment in advance or may suspend any further deliveries or continuance of the work to be performed by the WesTech Engineering, LLC until such payment has been received.

7. ESCALATION: If between the proposal date and actual procurement and through no fault of the Seller, the relevant cost of labor, material, freight, tariffs, and other Seller costs combined relating to the contract, increase by greater than 2.5% of the overall contract price, then the contract price shall be subject to escalation and increased. Such increase shall be verified by documentation and the amount of contract price escalation shall be calculated as either the actual increased cost to the Seller or, if agreed by the Parties, the equivalent increase of a relevant industry recognized third-

party index, and in both cases without any additional profit or margin being added.

8. APPROVAL: If approval of equipment submittals by Purchaser or others is required, a condition precedent to WesTech Engineering, LLC supplying any equipment shall be such complete approval.

9. INSTALLATION SUPERVISION: Prices quoted for equipment do not include installation supervision. WesTech Engineering, LLC recommends and will, upon request, make available, at WesTech Engineering, LLC's then current rate, an experienced installation supervisor to act as the Purchaser's employee and agent to supervise installation of the equipment. Purchaser shall at its sole expense furnish all necessary labor equipment, and materials needed for installation.

Responsibility for proper operation of equipment, if not installed by WesTech Engineering, LLC or installed in accordance with WesTech Engineering, LLC's instructions, and inspected and accepted in writing by WesTech Engineering, LLC, rests entirely with Purchaser; and any work performed by WesTech Engineering, LLC personnel in making adjustment or changes must be paid for at WesTech Engineering, LLC's then current per diem rates plus living and traveling expenses.

WesTech Engineering, LLC will supply the safety devices described in this proposal or shown in WesTech Engineering, LLC's drawings furnished as part of this order but excepting these, WesTech Engineering, LLC shall not be required to supply or install any safety devices whether required by law or otherwise. The Purchaser hereby agrees to indemnify and hold harmless WesTech Engineering, LLC from any claims or losses arising due to alleged or actual insufficiency or inadequacy of the safety devices offered or supplied hereunder, whether specified by WesTech Engineering, LLC or Purchaser, and from any damage resulting from the use of the equipment supplied hereunder.

10. ACCEPTANCE OF PRODUCTS: Products will be deemed accepted without any claim by Purchaser unless written notice of non-acceptance is received by WesTech Engineering, LLC within 30 days of delivery if shipped F.O.B. point of shipment, or 48 hours of delivery if shipped F.O.B. point of destination. Such written notice shall not be considered received by WesTech Engineering, LLC unless it is accompanied by all freight bills for said shipment, with Purchaser's notations as to damages, shortages and conditions of equipment, containers, and seals. Non-accepted products are subject to the return policy stated below.

11. TAXES: Any federal, state, or local sales, use or other taxes applicable to this transaction, unless specifically included in the price, shall be for Purchaser's account.

12. TITLE: The equipment specified herein, and any replacements or substitutes therefore shall, regardless of the manner in which affixed to or used in connection with realty, remain the sole and personal property of WesTech Engineering, LLC until the full purchase price has been paid. Purchaser agrees to do all things necessary to protect and maintain WesTech Engineering, LLC's title and interest in and to such equipment; and upon Purchaser's default, WesTech Engineering, LLC may retain as liquidated damages any and all partial payments made and shall be free to enter the premises where such equipment is located and remove the same as its property without prejudice to any further claims on account of damages or loss which WesTech Engineering, LLC may suffer from any cause.

13. INSURANCE: From date of shipment until the invoice is paid in full, Purchaser agrees to provide and maintain at its expense, but for WesTech Engineering, LLC's benefit, adequate insurance including, but not limited

to, builders risk insurance on the equipment against any loss of any nature whatsoever.

14. SHIPMENTS: Any shipment of delivery dates recited represent WesTech Engineering, LLC's best estimate but no liability, direct or indirect, is assumed by WesTech Engineering, LLC for failure to ship or deliver on such dates.

WesTech Engineering, LLC shall have the right to make partial shipments; and invoices covering the same shall be due and payable by Purchaser in accordance with the payment terms thereof. If Purchaser defaults in any payment when due hereunder, WesTech Engineering, LLC may, without incurring any liability therefore to Purchaser or Purchaser's customers, declare all payments immediately due and payable with maximum legal interest thereon from due date of said payment, and at its option, stop all further work and shipments until all past due payments have been made, and/or require that any further deliveries be paid for prior to shipment.

If Purchaser requests postponements of shipments, the purchase price shall be due and payable upon notice from WesTech Engineering, LLC that the equipment is ready for shipment; and thereafter any storage or other charge WesTech Engineering, LLC incurs on account of the equipment shall be for the Purchaser's account.

If delivery is specified at a point other than WesTech Engineering, LLC or its supplier's shipping points, and delivery is postponed or prevented by strike, accident, embargo, or other cause beyond WesTech Engineering, LLC's reasonable control and occurring at a location other than WesTech Engineering, LLC or its supplier's shipping points, WesTech Engineering, LLC assumes no liability in delivery delay. If Purchaser refuses such delivery, WesTech Engineering, LLC may store the equipment at Purchaser's expense. For all purposes of this agreement such tender of delivery or storage shall constitute delivery.

15. WARRANTY: WesTech Engineering, LLC warrants equipment it supplies only in accordance with the attached WesTech Warranty. This warranty is expressly given by WesTech and accepted by purchaser in lieu of all other warranties whether written, oral, express, implied, statutory or otherwise, including without limitation, warranties of merchantability and fitness for particular purpose. WesTech neither accepts nor authorizes any other person to assume for it any other liability with respect to its equipment. WesTech shall not be liable for normal wear and tear, corrosion, or any contingent, incidental, or consequential damage or expense due to partial or complete inoperability of its equipment for any reason whatsoever. The purchaser's exclusive and only remedy for breach of this warranty shall be the repair and or replacement of the defective part or parts within a reasonable time of WesTech's accepting the validity of a warranty claim made by the purchaser.

16. PATENTS: WesTech Engineering, LLC agrees that it will, at its own expense, defend all suits or proceedings instituted against Purchaser and pay any award of damages assessed against it in such suits or proceedings, so far as the same are based on any claim that the said equipment or any part thereof constitutes an infringement of any apparatus patent of the United States issued at the date of this Agreement, provided WesTech Engineering, LLC is given prompt notice in writing of the institution or threatened institution of any suit or proceeding and is given full control of the defense, settlement, or compromise of any such action; and Purchaser agrees to give WesTech Engineering, LLC needed information, assistance, and authority to enable WesTech Engineering, LLC so to do. In the event said equipment is held or conceded to infringe such a patent, WesTech Engineering, LLC shall have the right at its sole option and expense to a) modify the equipment to be non-infringing, b) obtain for Purchaser the license to continue using said equipment, or c) accept return of the equipment and refund to the Purchaser the purchase price thereof less a reasonable charge for the use thereof. WesTech Engineering, LLC will reimburse Purchaser for actual out-of-pocket expenses, exclusive of legal fees, incurred in preparing such information and rendering such assistance

at WesTech Engineering, LLC's request. The foregoing states the entire liability of WesTech Engineering, LLC, with respect to patent infringement; and except as otherwise agreed to in writing, WesTech Engineering, LLC assumes no responsibility for process patent infringement.

17. SURFACE PREPARATION AND PAINTING: If furnished, shop primer paint is intended to serve only as minimal protective finish. WesTech Engineering, LLC will not be responsible for the condition of primed or finish painted surfaces after equipment leaves its shops. Purchasers are invited to inspect paint in shops for proper preparation and application prior to shipment. WesTech Engineering, LLC assumes no responsibility for field surface preparation or touch-up of shipping damage to paint. Painting of fasteners and other touch-up to painted surfaces will be by Purchaser's painting contractor after mechanism installation.

Motors, gear motors, and other components not manufactured by WesTech Engineering, LLC will be painted with that manufacturer's standard paint system. It is WesTech Engineering, LLC's intention to ship major steel components as soon as fabricated, often before drive, motors, and other manufactured components. Unless Purchaser can ensure that shop primed steel shall be field painted within thirty (30) days after arrival at the job site, WesTech Engineering, LLC encourages the Purchaser to order these components without primer.

WesTech Engineering, LLC's prices are based on paints and surface preparations as outlined in the main body of this proposal. In the event that an alternate paint system is selected, WesTech Engineering, LLC requests that Purchaser's order advise of the paint selection. WesTech Engineering, LLC will then either adjust the price as may be necessary to comply or ship the material unpainted if compliance is not possible due to application problems or environmental controls.

18. CANCELLATION, SUSPENSION, OR DELAY: After acceptance by WesTech Engineering, LLC, this proposal, or Purchaser's order based on this proposal, shall be a firm agreement and is not subject to cancellation, suspension, or delay except upon payment by Purchaser of appropriate charges which shall include all costs incurred by WesTech Engineering, LLC to date of cancellation, suspension, or delay plus a reasonable profit. Additionally, all charges related to storage and/or resumption of work, at WesTech Engineering, LLC's plant or elsewhere, shall be for Purchaser's sole account; and all risks incidental to storage shall be assumed by Purchaser.

19. FORCE MAJEURE: Neither party hereto shall be liable to the other for default or delay in delivery caused by extreme weather or other act of God, strike or other labor shortage or disturbance, fire, accident, war or civil disturbance, act of government, pandemic, delay of carriers, failure of normal sources of supply, complete or partial shutdown of plant by reason of inability to attain sufficient raw materials or power, and/or other similar contingency beyond the reasonable control of the respective parties. The time for delivery specified herein shall be extended during the continuance of such conditions, or any other cause beyond such party's reasonable control. Escalation resulting from a Force Majeure event shall be equitably adjusted per the escalation policy stated above.

20. RETURN OF PRODUCTS: No products may be returned to WesTech Engineering, LLC without WesTech Engineering, LLC's prior written permission. Said permission may be withheld by WesTech Engineering, LLC at its sole discretion.

21. BACKCHARGES: WesTech Engineering, LLC will not approve or accept backcharges for labor, materials, or other costs incurred by Purchaser or others in modification, adjustment, service, or repair of WesTech Engineering, LLC furnished materials unless such back charge has been authorized in advance in writing by a WesTech Engineering, LLC purchase order, or work requisition signed by WesTech Engineering, LLC.

22. INDEMNIFICATION: Purchaser agrees to indemnify WesTech Engineering, LLC from all costs incurred, including but not limited to court costs and reasonable attorney fees, from enforcing any provisions of this contract, including but not limited to breach of contract or costs incurred in collecting monies owed on this contract.

23. ENTIRE AGREEMENT: This proposal expresses the entire agreement between the parties hereto superseding any prior understandings and is not subject to modification except by a writing signed by an authorized officer of each party.

24. MOTORS AND MOTOR DRIVES: In order to avoid shipment delays of WesTech Engineering, LLC equipment, the motor drives may be sent directly to the job site for installation by the equipment installer. Minor fit-up may be required.

25. EXTENDED STORAGE: Extended storage instructions will be part of information provided to shipment. If equipment installation and start-up is delayed more than 30 days, the provisions of the storage instructions must be followed to keep WARRANTY in force.

26. LIABILITY: Professional liability insurance, including but not limited to, errors and omissions insurance, is not included. In any event, liability for errors and omissions shall be limited to the lesser of \$100,000 USD or the value of the particular piece of equipment (not the value of the entire order) supplied by WesTech Engineering, LLC against which a claim is sought.

27. ARBITRATION NEGOTIATION: Any controversy or claim arising out of or relating to the performance of any contract resulting from this proposal or

contract issued, or the breach thereof, shall be settled by arbitration in accordance with the Construction Industry Arbitration Rules of the American Arbitration Association, and judgment upon the award rendered by the arbitrator(s) may be entered to any court having jurisdiction.

ACCEPTED BY PURCHASER

Customer Name: _____

Customer Address: _____

Contact Name: _____

Contact Phone: _____

Contact Email: _____

Signature: _____

Printed Name: _____

Title: _____

Date: _____

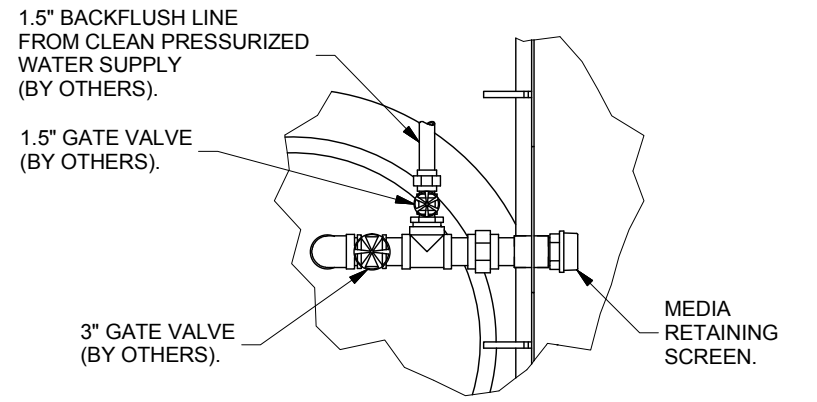
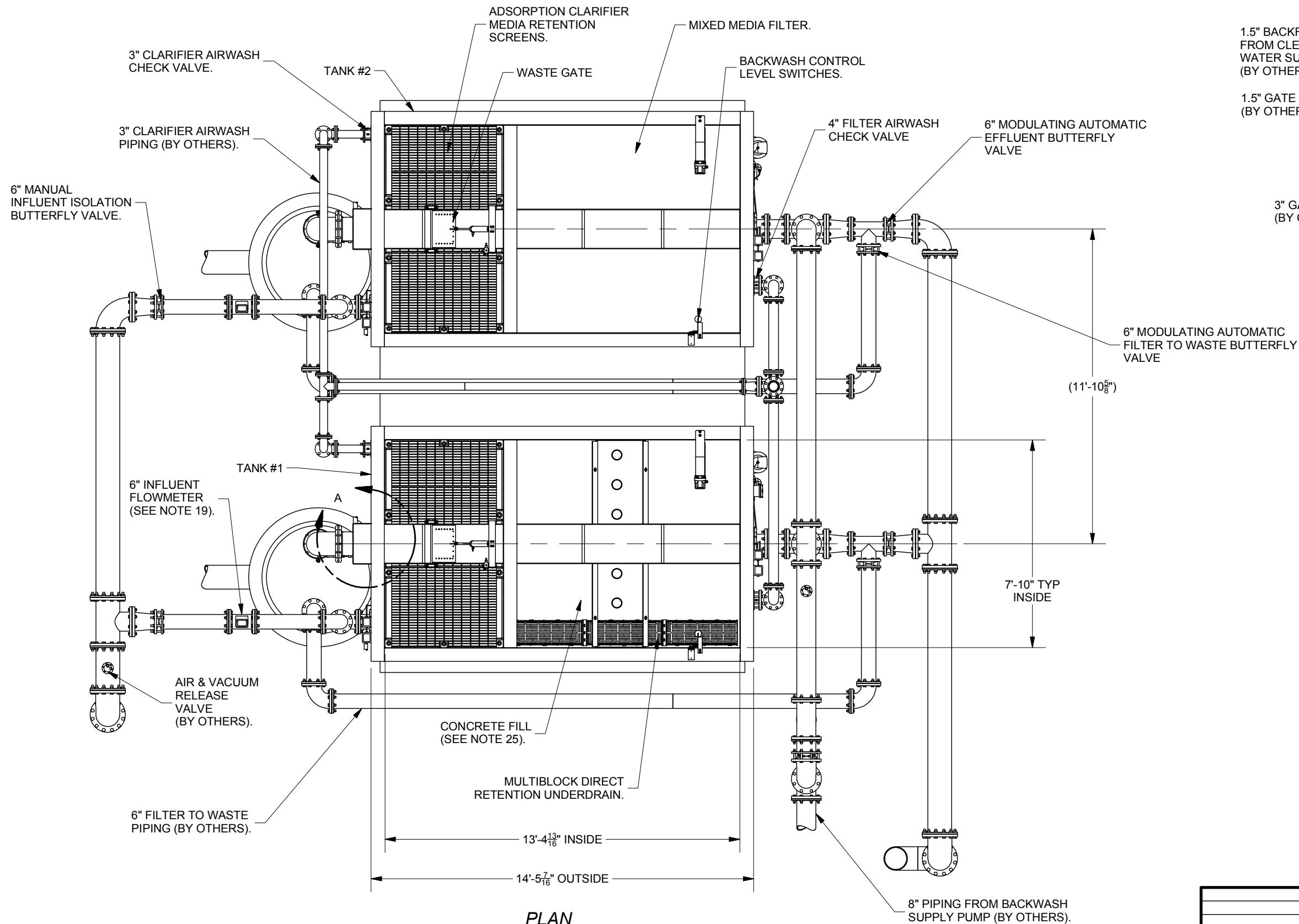

PLAN
 FILTER MEDIA AND MOST UNDERDRAIN
 LATERALS ARE REMOVED IN TANK #1

TRIDENT® PROCESS DESIGN INFORMATION		
DESIGN FLOW:	700	GPM
CLARIFIER LOADING RATE:	10	GPM/SQ FT
CLARIFIER AIR SCOUR FLOW:	200	SCFM
FILTER LOADING RATE:	5	GPM/SQ FT
FILTER BW FLOW, HIGH RATE:	1,050 @ 60	GPM @ °F
FILTER BW FLOW, LOW RATE:	350 @ 60	GPM @ °F
FILTER AIR SCOUR FLOW:	400	SCFM

PREPARED FOR			
ENGINEER			
CONTRACTOR			
PO/CONTRACT NUMBER			

WestTech			
<small>THIS DRAWING IS PROPERTY OF WESTTECH ENGINEERING, INC. AND IS TRANSMITTED IN CONFIDENCE. NEITHER RECEIPT NOR POSSESSION CONFERS OR TRANSFERS ANY RIGHTS TO REPRODUCE, USE, OR DISCLOSE, IN WHOLE OR IN PART, DATA CONTAINED HEREIN FOR ANY PURPOSE, WITHOUT THE WRITTEN PERMISSION OF WESTTECH ENGINEERING, INC.</small>			
TITLE GENERAL ARRANGEMENT, TR-210A, AA TRIDENT® TR-210A WATER TREATMENT SYSTEM			
DESIGNER	CHECKER	APPROVER	DATE
BA91	SH40	JA20	2012-06-20
DOCUMENT NUMBER			SHEET
9001054000			1 OF 4
			REV
			-

REV	REVISION DESCRIPTION	ECN	DESIGNER	APPROVER	DATE	REFERENCE DOCUMENTS

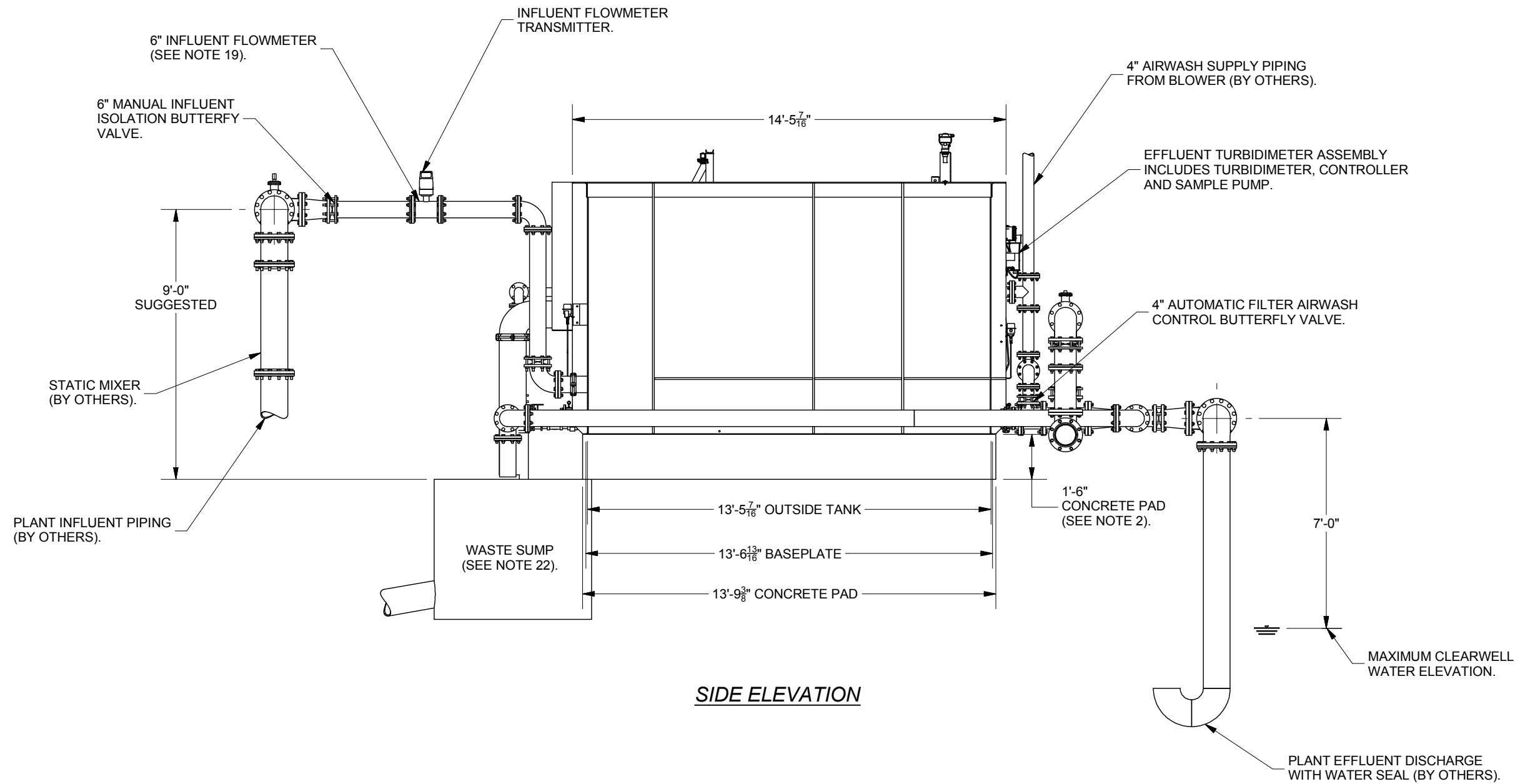

SIDE ELEVATION

WESTECH			
<small>THIS DRAWING IS PROPERTY OF WESTECH ENGINEERING, INC. AND IS TRANSMITTED IN CONFIDENCE. NEITHER RECEIPT NOR POSSESSION CONFERS OR TRANSFERS ANY RIGHTS TO REPRODUCE, USE, OR DISCLOSE, IN WHOLE OR IN PART, DATA CONTAINED HEREIN FOR ANY PURPOSE, WITHOUT THE WRITTEN PERMISSION OF WESTECH ENGINEERING, INC.</small>			
TITLE GENERAL ARRANGEMENT, TR-210A, AA TRIDENT® TR-210A WATER TREATMENT SYSTEM			
DESIGNER	CHECKER	APPROVER	DATE
BA91	SH40	JA20	2012-06-20
DOCUMENT NUMBER			SHEET
9001054000			2 OF 4
			REV
			-

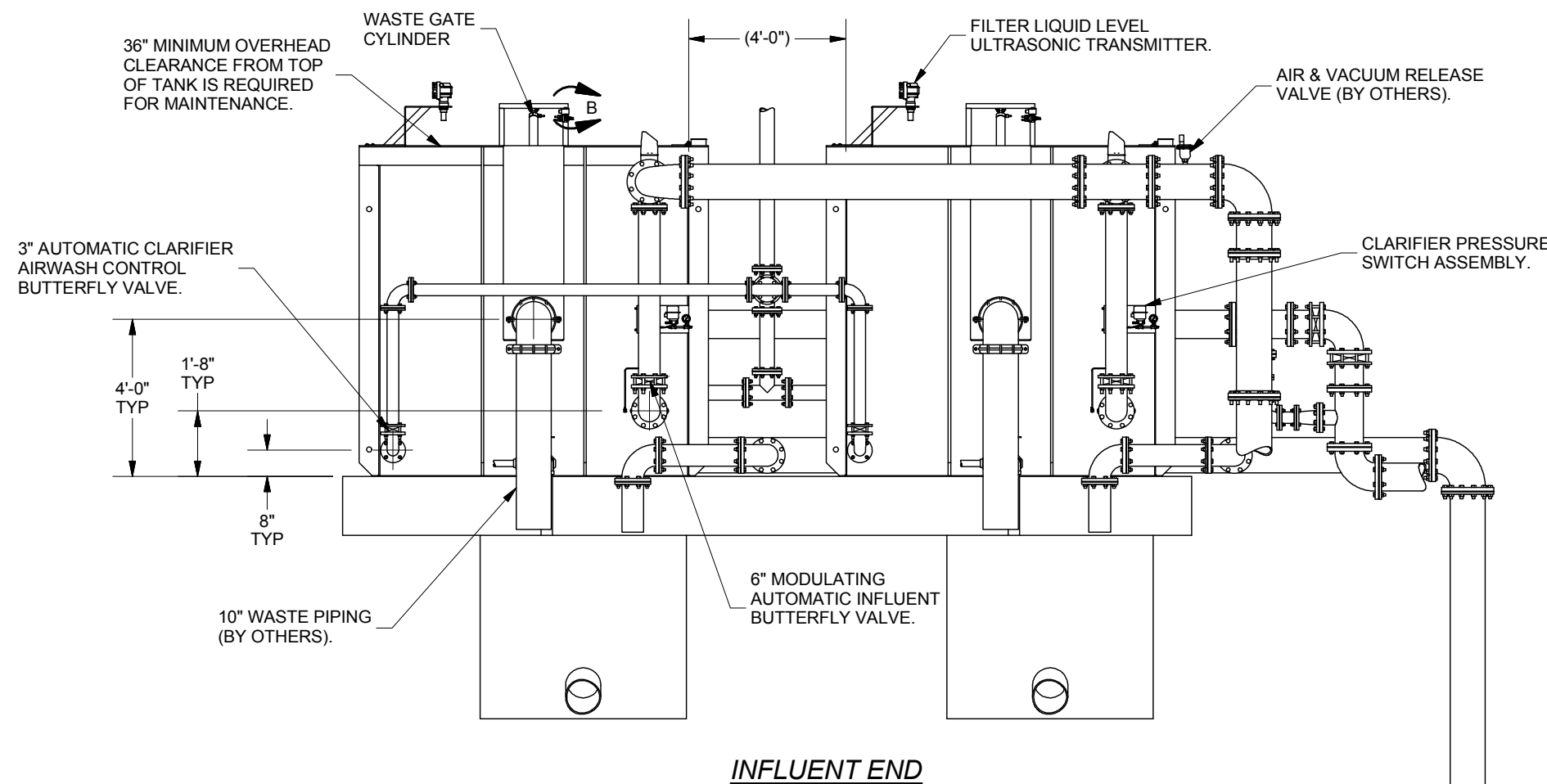

INFLUENT END

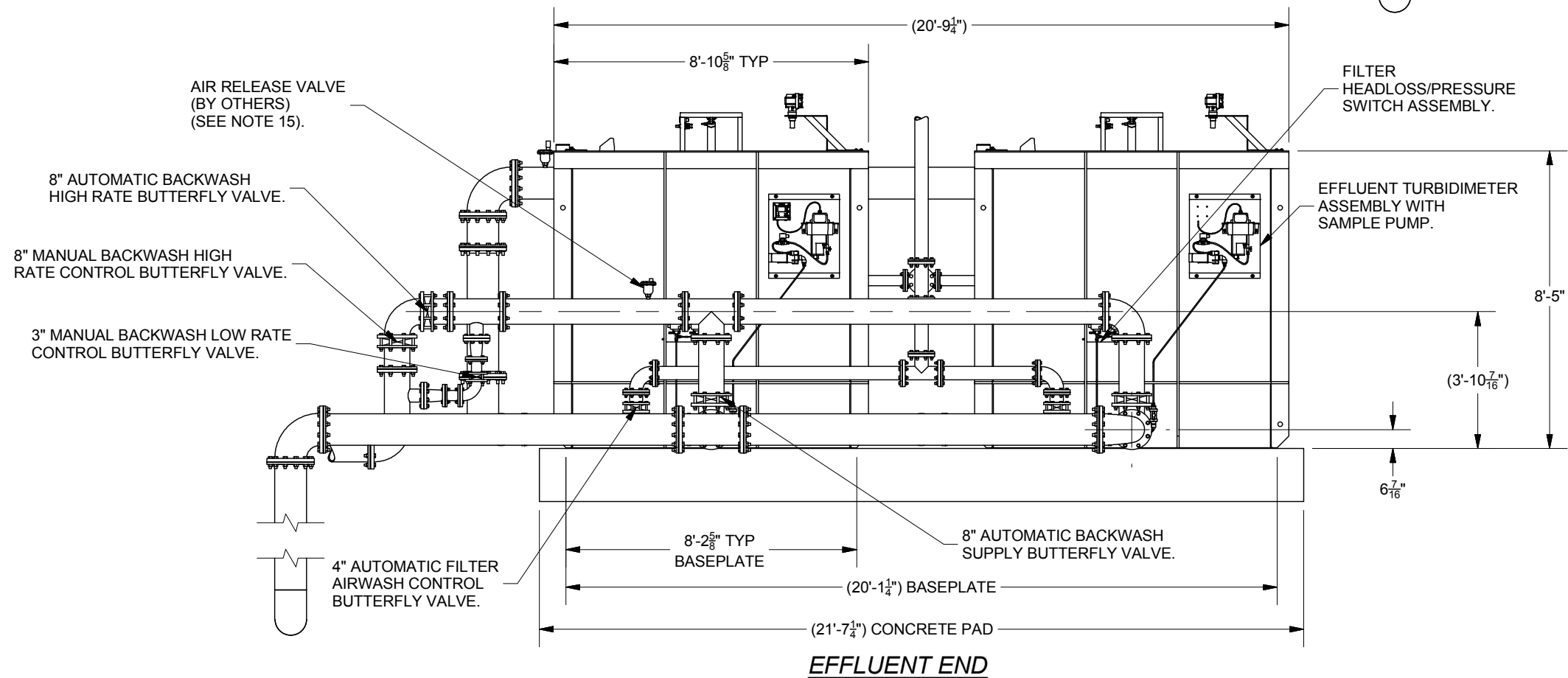

EFFLUENT END

WestTech			
THIS DRAWING IS PROPERTY OF WESTTECH ENGINEERING, INC. AND IS TRANSMITTED IN CONFIDENCE. NEITHER RECEIPT NOR POSSESSION CONFERS OR TRANSFERS ANY RIGHTS TO REPRODUCE, USE, OR DISCLOSE, IN WHOLE OR IN PART, DATA CONTAINED HEREIN FOR ANY PURPOSE, WITHOUT THE WRITTEN PERMISSION OF WESTTECH ENGINEERING, INC.			
TITLE GENERAL ARRANGEMENT, TR-210A, AA TRIDENT® TR-210A WATER TREATMENT SYSTEM			
DESIGNER	CHECKER	APPROVER	DATE
BA91	SH40	JA20	2012-06-20
DOCUMENT NUMBER			SHEET
9001054000			3 OF 4
			REV
			-

NOTES:

- 1.) EQUIPMENT FURNISHED BY WESTECH ENGINEERING IS DESCRIBED IN A SEPARATE EQUIPMENT LIST. ADDITIONAL PIPING, PIPE SUPPORTS, AND CONNECTION FITTINGS ARE NOT INCLUDED WITH STANDARD UNIT. MAJOR EQUIPMENT AND COMPONENTS TO BE INSTALLED AT JOBSITE, BY INSTALLING CONTRACTOR.
- 2.) EQUIPMENT CONCRETE PAD DESIGN IS THE RESPONSIBILITY OF THE CONSULTING ENGINEER.
- 3.) PIPE SUPPORTS ARE NOT SHOWN. SUPPORTS TO BE DESIGNED BY THE CONSULTING ENGINEER AND SUPPLIED BY THE INSTALLING CONTRACTOR. DO NOT SUPPORT PIPING OR OTHER STRUCTURES FROM THE TANK OR TANK PROJECTIONS.
- 4.) DESIGN AND APPLICATION FEATURES ARE DESCRIBED IN TYPICAL SPECIFICATION SHEETS, TECHNICAL DATA SHEET, FLOW SCHEMATIC, ELECTRICAL DIAGRAM AND ELECTRICAL SCHEMATIC. ARRANGEMENT SHOWN IS FOR BELOW-GRADE FINISHED WATER STORAGE.
- 5.) THE STANDARD DESIGN IS FOR INDOOR INSTALLATION.
- 6.) CHECK VALVES OR BACKFLOW PREVENTERS ARE REQUIRED IN BACKWASH LINES AND FURNISHED BY OTHERS (NOT SHOWN ON DRAWING).
- 7.) AUTOMATIC RATE OF FLOW CONTROL LOOPS ON EACH INFLUENT LINE MAINTAIN THE PRE-SET FLOW TO EACH UNIT. INFLUENT FLOW SET POINT MAY BE SET BY THE PLANT OPERATOR USING THE OIT. INFLUENT FLOW CONTROL IS INTERLOCKED WITH FLUSH AND BACKWASH CYCLES.
- 8.) FILTER LIQUID LEVEL CONTROLLERS OPERATE FILTER EFFLUENT AND FILTER-TO-WASTE MODULATING VALVES TO MAINTAIN CONSTANT FILTER LEVEL.
- 9.) CONTROL CIRCUITS PROVIDE FOR AUTOMATIC FLUSH AND BACKWASH CYCLE WITH RETURN TO OPERATING SERVICE, INITIATED BY TIME CLOCK, HIGH HEADLOSS, OR MANUAL PUSHBUTTON.
- 10.) THREE LEVEL SWITCHES WITH DRY CONTACTS SHOULD BE PROVIDED BY THE CUSTOMER AND INSTALLED IN THE FINISHED WATER STORAGE TANK FOR THE AUTOMATIC OPERATION OF THE TRIDENT UNITS. ONE HIGH LEVEL SWITCH WILL STOP THE UNITS, ONE MID LEVEL SWITCH WILL START THE UNITS AND ONE LOW LEVEL SWITCH WILL SERVE AS A MINIMUM LEVEL TO ENABLE THE BACKWASH PROCESS.
- 11.) THE HIGH LEVEL STOP AND THE MID LEVEL START SWITCHES SHOULD BE INSTALLED WITH SUFFICIENT VOLUME BETWEEN THEM TO PREVENT EXCESSIVE CYCLING OF THE TRIDENT UNITS.
- 12.) THE LOW LEVEL BACKWASH ENABLE SWITCH SHOULD BE INSTALLED WHERE THE MINIMUM VOLUME IN THE BACKWASH SUPPLY TANK IS ADEQUATE TO PROVIDE A BACKWASH WITHOUT PULLING AIR INTO THE BACKWASH SUPPLY PUMP. THE MAXIMUM WATER TEMPERATURE SHOULD BE CONSIDERED WHEN CALCULATING THE MINIMUM BACKWASH VOLUME OR LEVEL IN THE TANK.
- 13.) AIRWASH BLOWER (TWO PROVIDED BY WESTECH ENGINEERING) AND BACKWASH SUPPLY PUMP (BY OTHERS) ARE NOT SHOWN.
- 14.) AIR COMPRESSOR (BY OTHERS) FOR VALVE OPERATION IS NOT SHOWN.
- 15.) AN AIR RELEASE VALVE (BY OTHERS) IS REQUIRED AT HIGH POINTS OF THE BACKWASH SUPPLY LINE TO VENT ACCUMULATED AIR. THE VALVE(S) ARE TO BE SIZED TO ALLOW THE COMPLETE VOLUME OF THE BACKWASH LINE FROM SOURCE TO FILTER, TO BE VENTED IN 20 SECONDS WITH DIFFERENTIAL OF APPROXIMATELY 10 PSIG, AND BE CAPABLE OF CONTINUOUSLY VENTING ACCUMULATED AIR. FOR INSTALLATIONS UTILIZING VERTICAL TURBINE OR "CAN-TYPE" PUMPS, A SEPARATE "TURBINE AIR VALVE" IS REQUIRED TO VENT THE AIR CONTENTS OF THE PUMP COLUMN WITHOUT LETTING THE AIR INTO THE BACKWASH PIPING.
- 16.) TANKS ARE FURNISHED WITH FINISH COATING SUITABLE FOR POTABLE WATER APPLICATIONS ON INTERIOR; UNIVERSAL PRIMER ON EXTERIOR. TANK BOTTOM IS UNPAINTED FOR INSTALLATION ON COAL TAR OR ASPHALTIC TYPE BASE MASTIC COMPOUND (BY OTHERS). TANKS SHOULD BE LEVEL WITHIN ONE EIGHTH INCH AT TIME OF INSTALLATION.
- 17.) OPTIONAL EQUIPMENT TO SUIT PROJECT REQUIREMENTS IS AVAILABLE. TYPICAL PROCESS EQUIPMENT OPTIONS INCLUDE:
 - A) ALTERNATE OR ADDITIONAL CHEMICAL FEED SYSTEMS.
 - B) RAW WATER TURBIDITY MONITORING.
 - C) INFLUENT IN-LINE STATIC MIXER.
 - D) INFLUENT STREAMING CURRENT DETECTOR.
 - E) pH MONITOR.
 - F) PLATFORM/WALKWAY CLIPS.
 - G) AIR COMPRESSOR FOR VALVE OPERATION.
- 18.) CONSULT WESTECH ENGINEERING FOR OTHER INFLUENT FLOW CONTROL OPTIONS.
- 19.) LOCATION OF FLOW METERS ARE TO BE PER FLOWMETER MANUFACTURER'S WRITTEN RECOMMENDATIONS CONFIRMED BY THE CONSULTING ENGINEER.
- 20.) INFLUENT OPERATING PRESSURE REQUIRED FOR CONTROLLING INFLUENT FLOW MUST BE 20 FEET MINIMUM AT THE TANK CONNECTION. FOR INFLUENT PRESSURE OVER 35 FEET OF HEAD, CONTACT WESTECH ENGINEERING. OPTIONAL STATIC MIXER WILL REQUIRE ADDITIONAL PRESSURE.
- 21.) DRY, FILTERED, COMPRESSED AIR, 1 SCFM PER TANK, FREE AIR AT 80 PSIG MINIMUM DISCHARGE PRESSURE IS REQUIRED TO OPERATE PNEUMATIC INSTRUMENTATION AND AUTOMATIC CONTROL VALVES. AIR COMPRESSOR AND RESEVOIR (BY OTHERS) SHOULD BE SIZED TO PREVENT EXCESSIVE CYCLING.
- 22.) WASTE SUMP AND SUMP PIPING (BY CUSTOMER) MUST BE SIZED TO GIVE FREE DISCHARGE WITH AN AIRBREAK, FOR MAXIMUM WASTE FLOW.
- 23.) WASTE TROUGH LIP IS POSITIONED ABOVE THE NORMAL OPERATING WATER LEVEL AND BELOW THE TOP OF THE TANK. THIS ALLOWS IT TO ACT AS AN EMERGENCY OVERFLOW.
- 24.) TANK CONNECTIONS ARE FURNISHED GROOVED FOR GROOVED STYLE FLEXIBLE COUPLINGS, WITH THE EXCEPTION OF AIR CONNECTIONS. COUPLINGS AND/OR FLANGE ADAPTERS ARE BY OTHERS.
- 25.) TRIDENT MODEL TR-210A TANKS REQUIRE APPROXIMATELY 1.9 CUBIC YARDS OF FILL CONCRETE IN FILTER PLENUM AREA. FILL CONCRETE AND UNDERDRAIN GROUT ARE BY OTHERS.
- 26.) PLANT CONTROL PANEL AND CHEMICAL FEED ASSEMBLIES NOT SHOWN.

WestTech

THIS DRAWING IS PROPERTY OF WESTECH ENGINEERING, INC. AND IS TRANSMITTED IN CONFIDENCE. NEITHER RECEIPT NOR POSSESSION CONFERS OR TRANSFERS ANY RIGHTS TO REPRODUCE, USE, OR DISCLOSE, IN WHOLE OR IN PART, DATA CONTAINED HEREIN FOR ANY PURPOSE, WITHOUT THE WRITTEN PERMISSION OF WESTECH ENGINEERING, INC.

TITLE **GENERAL ARRANGEMENT, TR-210A, AA**
TRIDENT® TR-210A WATER TREATMENT SYSTEM

DESIGNER	CHECKER	APPROVER	DATE	
BA91	SH40	JA20	2012-06-20	
DOCUMENT NUMBER			SHEET	REV
9001054000			4 OF 4	-



**City of Upland
AC**

**AWC AC Proposal
for
TKE Engineering, Inc.
AWC Reference No.: 43560**

SUBMITTED BY:

9087A 198 Street
Langley, British Columbia V1M 3B1



Main Contact

Name: Ryan Harvey

Telephone: 604 364 2405

Email: ryanh@awcsolutions.com



June 30, 2022

Attn: Travis Bradshaw
TKE Engineering, Inc.
2305 Chicago Ave
Riverside, CA 92507, USA

RE: AWC: 43560 City of Upland - AC

Thank you for the opportunity to submit this proposal for an AWC AC for the treatment of raw water from the San Antonio Canyon in the City of Upland.

AWC provides complete water and wastewater treatment solutions for communities and industry. We focus exclusively on supplying and servicing equipment that requires worry free operation day-in and day-out. With a broad product offering and extensive in-house expertise, we offer our customers complete treatment solutions from process selection to commissioning and long-term support.

AWC, and its predecessor companies, have been providing water and wastewater treatment systems for over 40 years with over 500 installations. A complete list of AWC AC installations is provided in Exhibit 3.

Located in Vancouver, Canada, we employ the following disciplines to provide a complete 'single-source' solution to any water or wastewater treatment requirement:

- A strong team of senior Engineers and Ph.Ds., to oversee the design
- Journeyman Technicians, to provide full start up/commissioning and maintenance/repair capabilities for everything we sell.
- CSA electrical panel shop for upgrades, modifications, or servicing, providing full life cycle support
- Combined 65,000 sq. ft. facility
- Full fabrication facility and machine shop, up to 20-ton lift capacity

With a full range of integrated services provided by highly experienced professionals, AWC is your one-stop-shop for packaged and modular turnkey treatment solutions. We work extremely hard to provide our clients with unmatched service and provide the best total value and experience possible. We look forward to a follow up conversation to discuss this proposal and answer any questions you may have.

Thank you for considering our proposal. If you have any questions, please do not hesitate to contact me at the coordinates below.

Sincerely,

A handwritten signature in blue ink, appearing to read 'Ryan Harvey', with a long horizontal stroke extending to the right.

Ryan Harvey, Business Development Manager
604 364 2405 | ryanh@awcsolutions.com



TABLE OF CONTENTS

1 AWC COMPANY OVERVIEW 4

1.1 Water and Wastewater Treatment Capabilities4

1.2 Certified Operators4

1.3 Project Execution Approach.....5

1.4 Facility6

2 BUDGETARY PROPOSAL..... 8

2.1 Detailed Scope of Supply – 700 US gpm 2 train AC9

2.2 Optional Equipment and Services..... 11

3 BUDGETARY PRICING..... 12

3.1 Pricing12

3.2 Currency 13

3.3 Terms and Conditions 13

3.4 Customer Scope of Supply 13

3.5 Shipping Terms 13

3.6 Schedule and Shipment..... 14

3.7 Warranty 14

EXHIBIT 1 DRAWINGS..... 15

EXHIBIT 2 AC BROCHURE 16

EXHIBIT 3 AC INSTALLATION LIST 17

APPENDIX A AWC TERMS AND CONDITIONS..... i

APPENDIX B STANDARD EQUIPMENT WARRANTY..... i



1 AWC COMPANY OVERVIEW

AWC Water Solutions Ltd. (AWC) designs and builds complete packaged and modular water and wastewater treatment systems. AWC has one of the most experienced groups of water and wastewater treatment experts in the industry. The team has decades of history in designing and successfully delivering one of the most widely recognized water treatment systems in the industry. Our in-house engineering and technical teams work with clients to select the best process and design a custom package to reliably meet environmental, financial, and quality standards for your project.

In addition to packaged and modular water treatment systems, AWC offers a wide variety of in-house services including engineering & design, fabrication & machining, automation & controls including an in-house panel shop, project management, and a full field service support team for all manufactured and distributed products.

AWC has a track record of supplying treatment plants to remote locations including permits, turnkey package plants, and site installation, startup, commissioning, operations, and training.

1.1 Water and Wastewater Treatment Capabilities

AWC and its predecessor companies have been in operation for over 40 years and have built over 500 packaged water and wastewater treatment plants. We have experience in both the municipal and industrial markets. We maintain close relationships with many world-leading Original Equipment Manufacturer (OEM) process suppliers enabling us to offer the high performance, state-of-the-art systems for our clients' applications at an affordable price due to our competitive OEM pricing. The inclusion of advanced process controls and remote monitoring to our systems enables us to monitor system performance long after the commissioning of the plant. Core to AWC's success is the ability to quickly assist clients, optimize their system performance or importantly troubleshoot operating challenges. As we control the designs of our systems, we are also able to upgrade original installations to meet increased capacity, increased water quality requirements or changing raw water quality.

1.2 Certified Operators

To add value for our clients, AWC has enhanced our field service offering by bringing on board a team of Level 4 operators. Our operators are now working with our technicians in the field resulting in significant reduction in the time to commission and train. Our operators bring an enhanced level of support offerings for our clients by being able to provide a range of services such as full plant Operations contracts for the life of the plant, routine maintenance and membrane CIP support, ongoing training, monthly reviews, remote diagnostics and troubleshooting support.

1.3 Project Execution Approach

AWC project execution follows a rigorous approach, based on processes and procedures used at the major EPCM companies (see Figure 1). This means our documentation and quality standards for project design, procurement, fabrication, assembly, testing, and startup are robust and thorough to minimize any risks to the Client when our package arrives at site. Our team includes senior engineering project managers that have executed large industrial projects for major blue-chip resource clients.

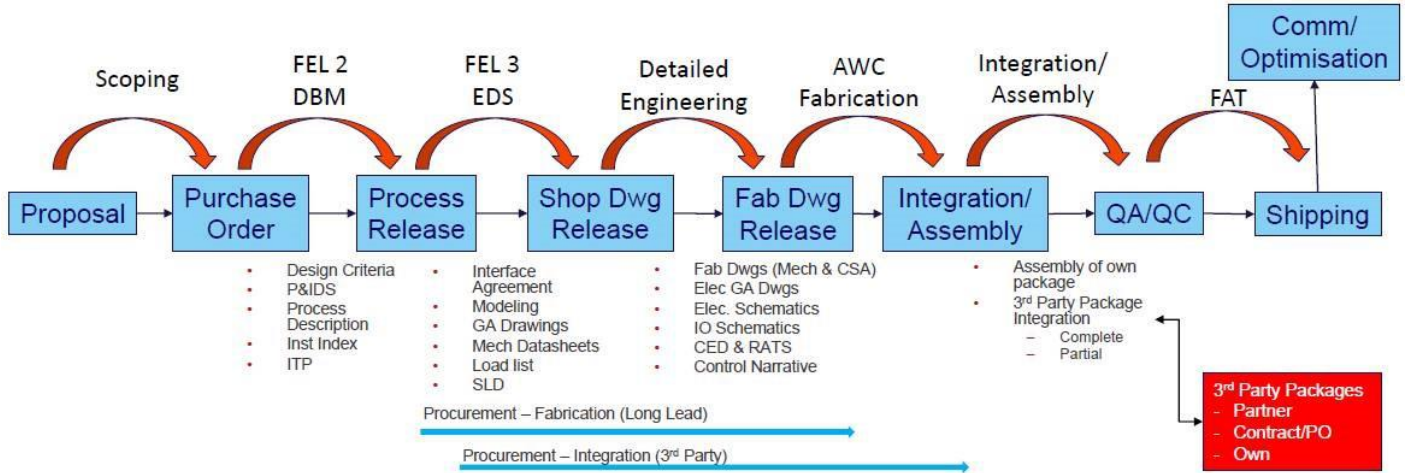

AWC strives to bring added value to our clients. We believe that with our experience, proprietary designs, manufacturing capabilities, our field service and full lifecycle support, we bring intangible value to our clients.

Typical AC system

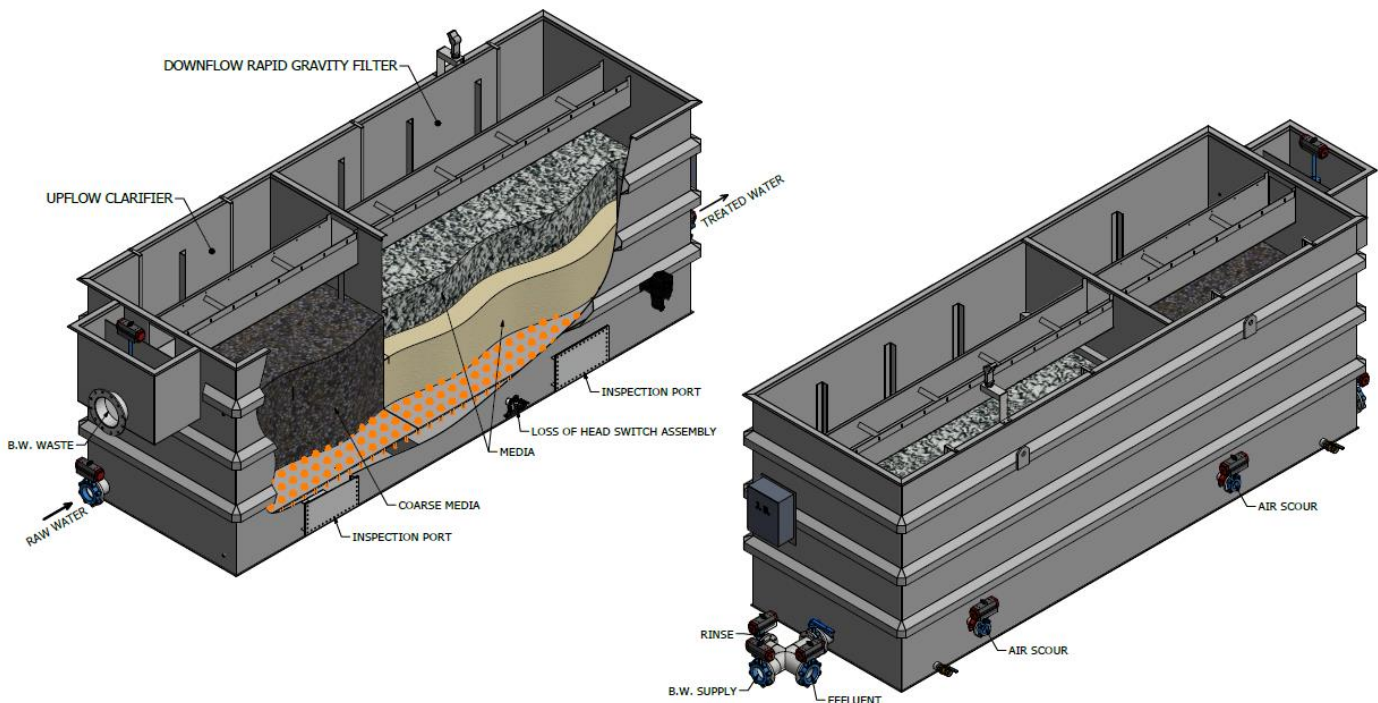

1.4 Facility

AWC has a 60,000 ft² integrated office, warehouse, and manufacturing facility in Langley, BC.

Fabrication



- 27,000 ft² Fabrication Area
- Specialized in Aluminum, Stainless, and Carbon Steel
- Four – Full Length Crane Bays
- 20+ Welding Machines
- 20-ton Lift Capacity
- Sheer & Plasma Cutting
- Hydrostatic Testing
- Large Round Tank Welding Rollers
- CWB 47.1 and 47.2, ASME B31.3 Certified / Compliant

Machine Shop



- Lathe (22"x90" capacity)
- Milling Machine (40" dia. c/w 30" vert. travel)
- Press Brake & Sheer
- 50-ton Press
- Industrial Parts Washer
- Multiple Band Saws (capacity up to 31.5")

Electrical Panel Shop

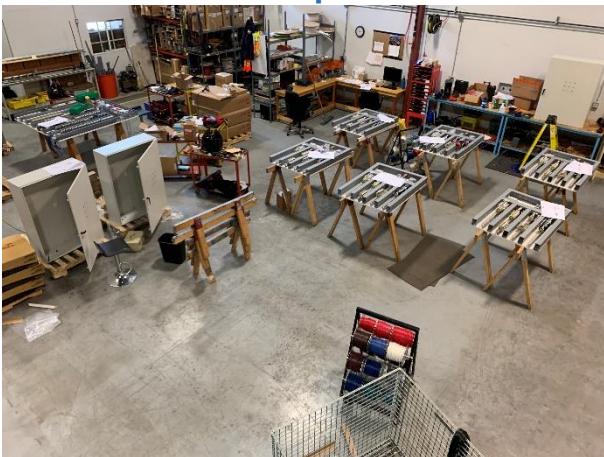

- CSA 22.2 & UL 508A certified
- 26' Overhead Clearance

Shipping / Receiving



- 18,000 ft² Indoor Warehouse
- Four Loading Bays, 3 at Grade
- 20-ton Lift Capacity (when crane loading)
- Four Forklifts (3,000-17,000 lbs)

Secured Yard



- Large Paved Yard Area (Fully Enclosed Portions)
- 24hr Monitored Security
- Large Crane and Truck Loading Area
- Local Off-Site Storage Capabilities

QA/QC Testing Capabilities



- Full Quality Assurance Program
- 10,000 USG Freshwater Storage Tank
- Water Recirculation Pumps (400-200gpm @ 20-85psi)
- Complete Water, Electrical and Automation Testing Station
- Up to 600V Capabilities

INDUSTRIES SERVED



Mining & Aggregates



Pulp & Paper



Food & beverage



Oil & Gas



Chemicals



Water & Wastewater

2 BUDGETARY PROPOSAL

AWC is pleased to provide a preliminary design and budget quotation for a packaged Absorption Clarifier (AC Clarifier). All AWC plants are manufactured, pre-assembled, and tested in our Langley, British Columbia facility prior to shipping. At this location we have an in-house panel shop, CWB certified fabrication facility, and a machine shop capable of manufacturing complete water and wastewater treatment systems.

AWC's scope includes the following project requirements:

- Process, mechanical, electrical and pipe design for the packaged or modular plant
- Drawing preparation including P&I, Layouts, Electrical and Mechanical
- Equipment fabrication
- System assembly
- Factory Acceptance Testing
- Shipping to site
- Commissioning and Training including O&M manuals
- Long Term support

AC Clarifier with Direct Filtration Water Treatment Plant in Apache Junction, Arizona





2.1 Detailed Scope of Supply – 700 US gpm 2 train AC

Plant Type AWC-AC-700-2

Two AC modules rated at 350 USgpm each, max plant flow 700 USgpm

A common static mixer will be provided, as well as individual inlet strainers per train. Each AC module comprises of an adsorption clarifier and a filter section

Clarification time	5.98 min
AC loading:	8.75 gpm/ft ²
Filtration time:	8.23 min'
Filter loading rate:	5.00 gpm/ft ²
Headloss: (Inlet AC to filter outlet)	21.5 ft (10 psi to 0.65 psi (gravity flow, 18" of head)
Average Backwash cycle:	1536 gpm for 6 minutes (total volume = 9216 Gal)
Average air scour cycle:	143 gpm for 6 minutes (total volume = 856 gal)

Note: The filter uses a combined air scour and water backflush filter cleaning system. An initial air scour at 4 scfm/ft² is followed by a combined air water wash at a wash rate of about 4-6 USgpm/ft², (10-15 m/hr), followed by a water only backflush at 12-16 USgpm/ft², (30-40 m/hr). The exact rates are established during start up.

Module Details				
Equipment	Quantity	Width	Height	Length
AC	2	8 ft	8.5 ft	17 ft

Chemicals				
Chemicals	PPM	Pump rate (gph)	Pump rate (gpd)	Tank (gal)
Polymer	0.5	5.84	140.2	65
Coagulant	30	1.95	46.73	65
Sulfuric acid	10	0.3	7.19	65

* Note, the chemicals indicated as well as the dosing is based on previous experience but should be confirmed through jar testing or during plant commissioning.



Summary of Electrical Loads

Project City of Upland
Plant AWC-AC-700-2
Ref # 43560

Description	Number	Phase	Voltage	kW	Total Connected load kW	Amps	Total kWh	Run Time per day Hours
Control Panel	2							
Instrumentation etc	1			1.00	1.00		24	24
Equipment								
Airscour blower	1	1	230	2.24	2.24		1.12	0.5
			Sub Total (kW)		2.24	20.36		
Mixers								
Soda Ash mixer	1	1	110	0.25	0.25		0.0625	0.25
Polymer mixer	1	1	110	0.25	0.25		0.0625	0.25
			Sub Total (kW)		0.50			
Dosing Pumps								
Chemical dosing pumps	3	1	110	0.15	0.45		10.8	24
			Sub Total (kW)		0.45	4.09		
		Total amps for plant (A)				33.55		
		Total load for plant (KWH)					36.05	

*Note: no process pumps, valving or other equipment considered in electrical summary table above

Maintenance:

Visually inspect for missing or damaged nozzles when the tank is drained. Look for large bubble formation as an indicator of nozzle damage. Replace if required.

Visually inspect media is level, check for mounding, craters causing irregular or uneven flow across the tank. Replenish filter media as required or use tools to redistribute media.

Usual maintenance on valves, instrumentation and control panel as per O&M manual.

304 Stainless steel: All modules are constructed of Constructed with 1/2" & 3/16" 304ss plate, 1/4" structural members offering corrosion free service and eliminating the need for painting and tank structure maintenance. Passivation of the pipe spool pieces on the tank are included in the price. Passivation of the tank is not included. The welds on the tank and spool pieces will be cleaned and not passivated. Passivation of the tank is available for a cost adder.

Note: budget option for aluminum provided. Passivation of any aluminum pipe spool piece or tank not included. Aluminum will be cleaned to a polished finish.

Individual Inlet flow control valve, meter and a common static mixer providing hydraulic flash mixing

Upflow flocculator / clarifier

- Inlet plenum with non-clogg Orthos nozzles
- (42") of crushed quartz media
- Backflushing by combined air scour/raw water flush
- Automatic control valve for air scour and backflush to waste

Gravity Sand Filter

- Plenum with non-clogg Orthos nozzles
18" of Anthracite and 12" of sand media
- Backwashing by combined air scour/water
- Automatic control valve for effluent, rinse, air scour, and backwash

Air scour blower rated for 556 scfm at open air flow

Instruments

- Inlet flowmeter
- Treated Water Turbidimeter
- Differential pressure transmitter for adsorption clarifie

Chemical Systems

- Polymer chemical dosing system, duplex dosing pumps, storage tank and mixer
- Coagulant chemical dosing system, duplex dosing pumps, storage tank and mixer
- Sulfuric acid chemical dosing system, duplex dosing pumps, storage tank and mixer

PLC control system & remote IO panel for fully automatic operation

Access ladder and walkway

A commissioning report

Operation and Maintenance Manual 1 digital and 3 hard copies

Startup, Commissioning and Training

2.2 Optional Equipment and Services

In addition to the AC standard scope of supply, AWC's integrated supply scope can be expanded to include:

- Filter Backwash pumps
- Effluent pumps
- Sludge pumps / sludge handling
- UV Disinfection systems
- Specialized media for advanced treatment of different contaminants. Specialized media can be added to the proposed multimedia filter or stand-alone pressure or gravity filter systems can be added. For example:
 - Greensand for manganese, iron and arsenic removal



- Granulated activated carbon for organics or PFOS removal
- SCADA and/or communication links to plant wide systems
- Backwash and rinse water recovery to achieve 99% recovery
- Complete skid mounting including modular building envelope for improved site installation schedule and reduced capital cost
- Operations and/or remote monitoring support including operator training or supervisory support.

Please consult with AWC for additional information on these options and budget pricing.

3 BUDGETARY PRICING

3.1 Pricing

AWC's Budgetary pricing is provided below. Note: This pricing is based on preliminary design based on limited project information and is subject to change. Pricing is to be used for budgeting purposes only.

Item	Qty	Description	Total
1	2	AWC-AC-700 Constructed with 1/2" & 3/16" 304ss plate, 1/4" structural members.	\$1,164,500
2	1	AWC-AC-700 (third optional train)	\$529,300
3	1	Startup, Commissioning and Training. Includes travel and living expenses	Included
4	1	Shipping to job site including insurance	Included
TOTAL:			\$1,693,800

Please see the aluminum cost option in the pricing table below.

Item	Qty	Description	Total
1	2	AWC-AC-700 Constructed with 1/4" marine grade aluminum, 5086 H116 or H32	\$1,060,000
2	1	AWC-AC-700 (third optional train)	\$473,900
3	1	Startup, Commissioning and Training. Includes travel and living expenses	Included
4	1	Shipping to job site including insurance	Included
TOTAL:			\$1,533,900

3.2 Currency

All pricing excludes taxes and is in USD.

3.3 Terms and Conditions

AWC Standard Terms and Conditions are attached in Appendix A for reference.

3.4 Customer Scope of Supply

The following is not included in AWC's scope and will be the responsibility of the customer on delivery:

- Receiving, unloading and suitable storage of material
- Cleaning of tanks and equipment following shipment, if required. Shrink wrapping or tarping of systems is available if shipping or security conditions require.
- Installation of all equipment supplied
- Site preparation, foundations and building work
- Piping connections, yard piping, drain piping, or other piping outside the tank, skid, or plant structures
- Design, supply, and installation of pipe connections between tanks and air blower(s) or backwash pumps
- Design, supply and installation of field electrical wiring and conduit between control panel(s) and junction boxes
- Minor re-termination of electrical wiring from equipment to junction boxes due to shipping constraints
- Backwash pumps and water supply
- Effluent pumps
- Permitting and approvals
- Sampling and lab testing for performance testing

3.5 Shipping Terms

DAP: The budgetary price includes shipping to site. Freight costs included are preliminary and subject to change. Offloading to be completed by others.



3.6 Schedule and Shipment

Shop drawings will be submitted for approval within (10-12) weeks after acceptance of Purchase Order. Fabrication will not commence until the Purchaser has indicated, in writing, approval of the shop drawings.

AWC assumes a (2) week drawing review by Purchaser.

Shipment is typically made within 40 weeks of approval of drawings. Delivery schedule is contingent on AWC receiving, in a timely manner, all required technical info, including drawing approval and all required commercial documents, delivery instructions, responses to RFIs, and other information requested.

NOTE: All schedules are preliminary and subject to change based on time of order and AWC fabrication facility capacity.

3.7 Warranty

AWC warranty has been included for reference as Appendix B Standard Equipment Warranty. Additional coverage is available, please contact your representative for details.

EXHIBIT 1 DRAWINGS

Sample Layout – Preliminary

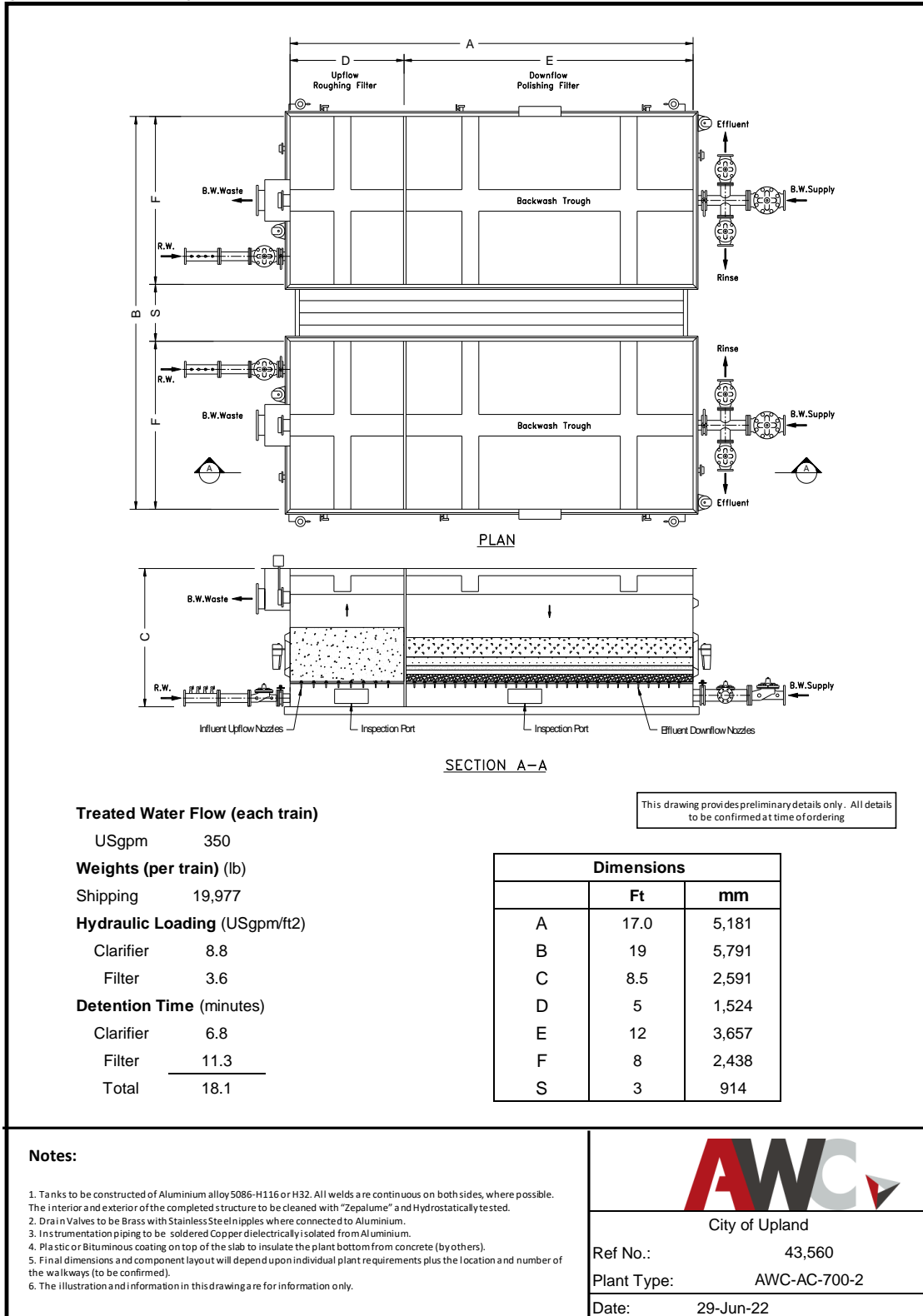



EXHIBIT 2 AC BROCHURE

ADSORPTION CLARIFICATION WATER TREATMENT PLANTS

AWC Water Solutions offers packaged and modular water and wastewater treatment plants including the Adsorption Clarifier (AC) process. AC plants incorporate a unique, backwashable upflow media clarifier which provides a "tortuous path" combined flocculation and clarification as the raw water passes through the media to the integrated Rapid Gravity Filter. This clarification extends the maximum turbidity of the AC plant compared to a Direct Filter plant while still maintaining a compact footprint and affordable price. AC plants are particularly suited for treating surface waters with a peak turbidity of 50 NTU and average turbidity less than 20 NTU. Options are available for removing organics, iron and manganese.

AWC AC plants are custom-designed to meet our clients' needs. The AC plant can treat capacities up to 2,000 gpm (10,800 m³/d) per train. Multiple trains can be combined for higher flows. They also reliably achieve less than 0.1 NTU turbidity and 2.5-log, multi-barrier protection against Giardia and Cryptosporidium with the integrated Rapid Gravity Filter. Systems are used for community and potable water supplies as well as pretreatment for industrial processes and NF and RO membranes.

HOW IT WORKS

FLASH MIXING

A coagulant added to the raw water precipitates dissolved contaminants & encourages suspended particles to form "flocs".

- Multi-chemical injection ports for coagulant, polymer, pH adjustment, etc. provides process flexibility
- Optional static or powered mixers

FLOCCULATION

As the water passes upward through the upflow clarifier filter, the flocs grow and are partially removed by the coarse media.

- Acts as both flocculation and clarification zone to reduce filter loading
- Compact footprint compared to conventional flocculation and clarification systems.
- Coarse angular gravel media for particulate retention

FILTRATION

A high-rate media filter removes remaining particles. Solids that accumulate within both the upflow and downflow filters are periodically removed by automatically controlled air/water backwashing.

- Mono, dual and multi-media options
- Options for iron, manganese and arsenic removal
- Options for water backwash and surface wash and air scour or water backwash for reduced water consumption and improved cleaning.
- Nozzle and plenum-type underdrain

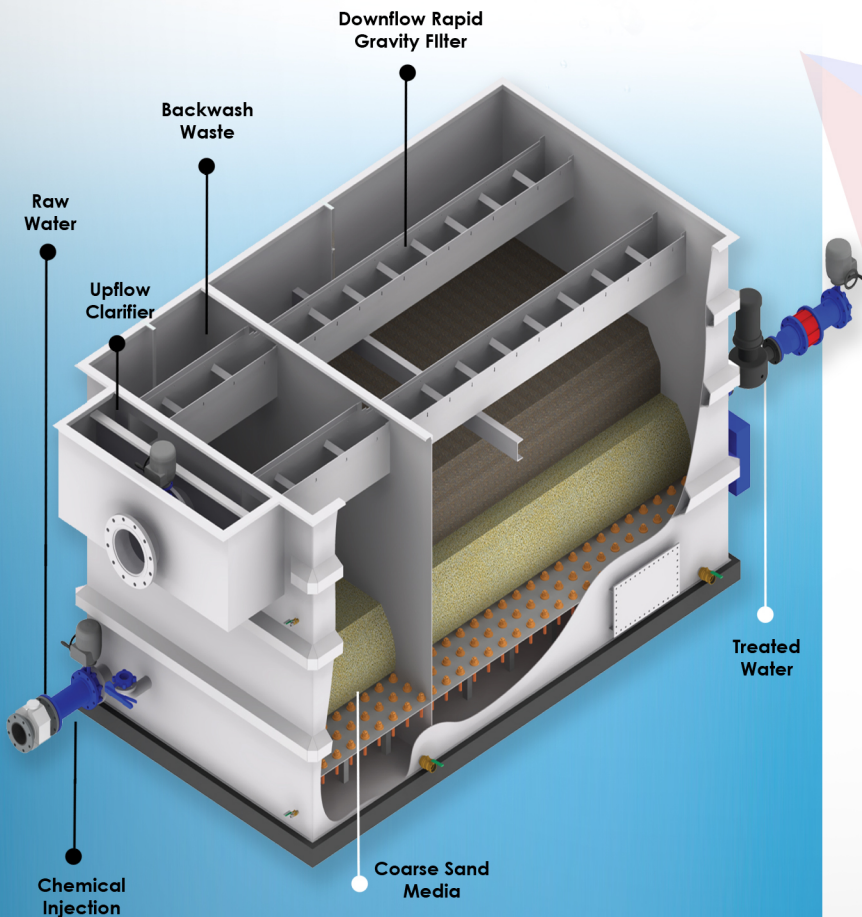

PLANT FEATURES

CORROSION-RESISTANT CONSTRUCTION

AWC constructs its tanks out of highly corrosion-resistant marine-grade, 5086 aluminum alloy achieving an EPA tank life rating of 100 years. This construction eliminates the need for corrosion-protection coatings and future recoating maintenance and prevents premature failures, which can occur with poor surface preparation or coating application. Sacrificial anodes are used to further increase protection. All fasteners in contact with the aluminum are 316 stainless steel to minimize galvanic corrosion. Stainless steel, epoxy coated steel or composite tanks are also available upon request.

ELECTRICAL SYSTEMS AND CONTROL PANELS

AWC designs, builds, programs and commissions fully integrated, automated control and electrical systems. Our systems feature:

- Integrated UL and CSA approved MCC's, drives and control panels
- Fully automatic operation with advanced instruments and controls
- Remote monitoring via SCADA, or PC/Tablet or smart phone options are available
- Industry standard PLC options for reduced training and technical support

CHEMICAL AND PUMPING SYSTEMS

AWC offers a full range of chemical mixing and dosing systems, including solution tanks, mixers, dosing pumps, spill containment and safety equipment. Well pumps, feed and distribution pumps skids are completely integrated with plant controls providing a seamless operation and control environment.

TECH SUPPORT AND REMOTE MONITORING

Full technical support services including telephone & emergency support, remote system monitoring and diagnostics, pilot programs & process optimization, performance audits, training, and upgrade planning are available.

ADVANTAGES OF AWC AC PLANTS

HIGH CAPACITY TREATMENT AND RETROFITS

Our process equipment components can also be supplied for installation into site-constructed concrete tanks or retrofitted into existing tankage. Capacities ranging to 100,000 m3/d (25 MGD) can be achieved in this manner. AWC can provide tank dimensions and other civil and building criteria to assist clients construct a complete plant.

COST-EFFECTIVE

Our packaged AC plants are pre-assembled and tested in our facility, often saving 50% or more over in-situ construction costs and schedule. The plant can also be integrated into pre-engineered building systems and shipped to site for increased savings. The small AC footprint reduces building costs.

SIMPLICITY

Our AC plants are quiet, simple and easy-to-operate with minimal operator input. They adjust quickly to rapidly changing process conditions. They are also supplied complete with chemical dosing, water quality instrumentation, automatic controls and monitoring systems customized to meet local needs. System start-up, commissioning and onsite customization by our PLC/process technicians assures performance objectives are achieved.



CAPACITY (gpm) (m3/d)		UPFLOW CLARIFIER (10 gpm/ft2) (25m/hr) GRAVITY FILTER (5 gpm/ft2) (12m/hr)			UPFLOW CLARIFIER (10 gpm/ft2) (25m/hr) GRAVITY FILTER (5 gpm/ft2) (12m/hr)			UPFLOW CLARIFIER (10 gpm/ft2) (25m/hr) GRAVITY FILTER (5 gpm/ft2) (12m/hr)			
		(ft) W (mm)	(ft) H (mm)	(ft) L (mm)	(ft) W (mm)	(ft) H (mm)	(ft) L (mm)	(ft) W (mm)	(ft) H (mm)	(ft) L (mm)	
50	250	3'0"	910	4'3"	1300	4'0"	1220	6'9"	2060	5'3"	1600
100	500	4'0"	1220	6'0"	1830	5'0"	1524	7'9"	2360	8'0"	2440
200	1000	6'0"	2440	7'9"	2360	6'0"	1830	7'9"	2360	13'9"	4190
400	2000	8'0"	1830	7'9"	2900	8'0"	2400	9'6"	2900	20'3"	6170
600	3000	8'0"	2440	9'6"	2900	8'0"	2440	9'6"	2900	30'3"	9220
800	4000	8'0"	2440	9'6"	2900	10'0"	3060	9'6"	2900	32'3"	9830
1000	5000	8'0"	2440	9'6"	2900	10'0"	3060	9'6"	2900	40'3"	12260

MULTIPLE TRAINS AVAILABLE

IMPERIAL / METRIC
DIMENSIONAL TABLE

ABOUT AWC WATER SOLUTIONS

AWC Water specializes in providing innovative packaged and modular water and wastewater treatment solutions for municipal and industrial applications. With more than 500 plants delivered around the world, we offer unmatched expertise and a reputation for delivering reliable, high quality water and wastewater solutions.

Contact AWC today to discuss your project needs.



AWC WATER SOLUTIONS LTD.
Tel. 604-638-0760 Fax. 604-638-0795
Email. info@awcwater.com



EXHIBIT 3 AC INSTALLATION LIST



Project List

Year	Customer & Location	Prov. / State	Country	Process System	Capacity, gpm	Capacity, m ³ /d	Sector
							Municipal
2022	Del Oro	CA	USA	AC Clarifier	700	3,816	
							Municipal
2021	Nunapitchuk	AK	USA	AC Clarifier	40	218	
2021	Central Bridge WD, Central Bridg	NY	USA	AC Clarifier, no filter	350	1,907	Municipal
2018	Stoney Rapid	SK	CAN	AC Clarifier	200	1,091	Municipal
2018	Eden Valley II	AB	CAN	AC Clarifier	185	1,010	Municipal
2017	Fleming Neon	KY	USA	AC Clarifier	500	2,727	Municipal
2016	Donner Summit	CA	USA	AC Clarifier	700	3,818	Municipal
2015	Apache Junction	AZ	USA	AC Clarifier	1,400	7,636	Municipal
2014	Rockingham	Roscommon	IE	AC Clarifier	1,100-2	6,000	Municipal
2014	Lisbrock	Roscommon	IE	AC Clarifier	880-2	4,800	Municipal
2014	Ballinagard	Roscommon	IE	AC Clarifier	1,144-2	6,236	Municipal
2013	Baffinland	NUN	CAN	AC Clarifier	15	82	Resources
2013	Paron	AR	USA	AC Clarifier	525-2	2,862-2	Municipal
2009	Etgo	QC	CAN	AC Clarifier	500	2,725	Resources
2008	Chetwynd	BC	CAN	AC Clarifier	1,100	5,995	Municipal
2005	Eden Valley	AB	CAN	AC Clarifier	185	1,008	First Nations
2005	Castlebaldwin	County Sligo	IE	AC Clarifier	120	654	
2005	Geevagh	County Sligo	IE	AC Clarifier	229	1,248	Municipal
2005	Southview	ON	CAN	AC Clarifier	88	480	Resort
2005	Brandywine	WV	USA	AC Clarifier	350	1,908	Municipal
2004	Andrews	NC	USA	AC Clarifier	1,400	7,630	Municipal
2003	Blue Lake Provincial Park	ON	CAN	AC Clarifier	30	164	Recreation
2003	Halfway Lake Prov.	ON	CAN	AC Clarifier	30	164	Recreation
2003	Pancake Bay Prov. Park	ON	CAN	AC Clarifier	40	218	Recreation
2003	Rushing River Provincial Park	ON	CAN	AC Clarifier	30	164	Recreation
2003	Metaline Falls	WA	USA	AC Clarifier	820	4,469	Municipal
2002	Cleveland	OK	USA	AC Clarifier	700	3,186	Municipal
2002	Amity	OR	USA	AC Clarifier	800	2,180	Municipal
2002	Possum Kingdom	TX	USA	AC Clarifier	900	4,905	Municipal
2002	Clones, County Monaghan		IE	AC Clarifier	460	2,507	Municipal
2001	Fruitvale	BC	CAN	AC Clarifier	1,200	6,540	Municipal
2001	Liberty	SK	CAN	AC Clarifier	36	196	Municipal
2001	Riverhurst	SK	CAN	AC Clarifier	100	545	Municipal
2001	Stony Rapids	SK	CAN	AC Clarifier	100	545	Municipal
2001	Imperial Valley	CA	USA	AC Clarifier	100	545	Municipal
2001	River Bend	WA	USA	AC Clarifier	80	436	Municipal
2000	Millport	AL	USA	AC Clarifier	350	1,908	Municipal
2000	Waterloo Springs, Cherokee Cou	AL	USA	AC Clarifier	1,400	7,630	Municipal
2000	Fort Stanton	NM	USA	AC Clarifier	75	409	Recreation
2000	Canyon Lake	TX	USA	AC Clarifier	1,400	7,631	Municipal
2000	Arlington	WA	USA	AC Clarifier	1,710	9,320	Municipal
1999	Warren Springs	AL	USA	AC Clarifier	1,400	7,630	Municipal
1999	Toyah	TX	USA	AC Clarifier	175	954	Municipal
1998	Willamina	OR	USA	AC Clarifier	700	3,815	Municipal
1996	City of Enderby	BC	CAN	AC Clarifier	734	4,000	Municipal
1996	Bath	ON	CAN	AC Clarifier	1,100	5,995	Municipal
1996	Neihart	MT	USA	AC Clarifier	100	545	Municipal
1995	Sandy Bay	SK	CAN	AC Clarifier	200	1,090	Municipal
1994	One Arrow First Nations	SK	CAN	AC Clarifier	30	164	First Nations
1991	Dept. of National Defence, Nana	BC	CAN	AC Clarifier & Pressure Filter	200	1,090	Institutional



APPENDIX A AWC TERMS AND CONDITIONS

DEFINITIONS:

- i. **"Agreement"** means the Buyer's agreement to purchase the Product(s) and/or Services from the Seller.
- ii. **"Buyer"** means the company, partnership, person, or entity purchasing the Product(s) and/or Services from the Seller identified in the Purchase Documents.
- iii. **"Product(s)"** means the equipment parts and materials being purchased by the Buyer identified in the Purchase Documents.
- iv. **"Purchase Documents"** means the documents accompanying these Terms and Conditions which more fully describe the Products and/or Services being purchased from the Seller, including, as applicable, the Buyer's request for quotation, purchase orders, and the Seller's quotation.
- v. **"AWC Solutions", "AWC" and "Seller"** means AWC Process Solutions Ltd or AWC Water Solutions Ltd.
- vi. **"Force Majeure"** means an event beyond reasonable control, including, without limitation, acts of God, earthquake, tsunami, storm, washout, landslide, avalanche or other extreme weather conditions, fire, flood, vandalism, explosions, strikes, lockouts or other industrial disturbances, unavailability of any goods, materials or equipment, acts of the Queen's or public enemies, wars, blockades, insurrections, riots, arrests, restraints or other civil disturbances, epidemics, restraints or prohibitions by any court or governmental board, department, commission or agency, and new or amended laws, and all other events of a similar nature.

2. APPLICATION: These terms and Conditions apply to every sale of Product(s) and every supply of Services by the Seller to the Buyer. The Buyer specifically agrees and acknowledges that unless the Seller agrees in writing to a modification of these Terms and Conditions, these Terms and Conditions apply and take precedence over any of the Buyer's Terms and Conditions whether set out in the Purchase Documents or otherwise.

3. PRICES: Unless otherwise specified by the Seller, the Seller's price for the sale of the Product(s) will remain in effect for forty-five (45) days from the date provided. The Seller's prices do not include applicable taxes which will be added to the price quoted and appear as a separate line item on the Seller's invoice. In case of any discrepancies between Buyer's Purchase Order and Seller's Order Confirmation it is the responsibility of Buyer to notify Seller within 24 hours of receiving the Seller's Order Confirmation after which point Buyer is bound to prices in Seller's Order Confirmation.

4. TERMS OF PAYMENT: Payment terms and schedule are of the essence. Subject to approval of the Seller's accounting department, the Buyer shall pay the Seller the price of the Product(s) and/or Services provided within thirty (30) days from the date of the Seller's invoice. If the Seller and the Buyer have agreed to a milestone payment schedule, the payment specified in the milestone payment schedule shall be paid on the dates that each milestone is achieved. All overdue payments bear interest commencing on the day on which the amount became payable, calculated at the rate of 1.2% per month compounded monthly (15.3895% per annum).

5. DELIVERY AND TRANSFER OF TITLE AND RISK: All delivery dates of the Product(s) and/or Services to be provided by the Seller are approximate only and are based on the Seller having received from the Buyer all information required by the Seller to provide the Product(s) and/or Services. Seller shall in good faith attempt to effect delivery by the date specified but shall not be responsible or liable for delays due to unexpected circumstances. In no event will Seller be liable for incidental or consequential damages resulting from failure to meet the specified or amended delivery dates. All Product(s) shall be delivered to the Buyer at the location indicated in the Purchase Documents, EX WORKS at the point of the manufacture of the Product(s). All risk of loss or damage to the Products while in transit shall be borne by the Buyer. Title to the Product(s) shall pass to the Buyer on the Buyer making payment in full for the Product(s) or on the Product(s) being delivered to the Buyer, whichever occurs later.

6. DOCUMENTATION: The Seller shall supply the Buyer with the documentation specified in the Seller's quotation. Any additional copies of the documentation or the supply of documentation on alternative media will be provided by the Seller to the Buyer at the Seller's price in effect at the time of the request.

7. INSTALLATION: The Buyer shall be responsible for transporting, receiving, storing, installing, starting up, and maintaining all Product(s). If requested, the Seller may, at its option, provide Services to assist the Buyer in the installation of the Product(s) at a price agreed upon between the Buyer and the Seller or at the rates set out in the Seller's published rate schedule at the time the Services are rendered.

8. EXCUSE OF PERFORMANCE: The Seller shall be excused from the performance of any term or condition of this sale or the provision of Services when and to the extent that the performance is delayed beyond its reasonable control including, without limitation to, acts of God, wars, riots, labour unrest, inability to obtain materials or components, explosions, accidents, governmental requests, laws, regulations, orders or actions. If such an event occurs, the delivery date and the price of the Product(s) and/or Services to be provided by the Seller may be revised by agreement made between the Buyer and the Seller or the Seller may at its option cancel the sale of the Product(s) or agreement to provide Services in which case the Buyer will pay the Seller any and all losses, damages, dismantling, restocking fees, and any other costs or expense incurred by the Seller arising from such a termination.

9. TERMINATION AND SUSPENSION: The Buyer may terminate or suspend its purchase of all the Product(s) and/or Services provided that it pays the Seller for any and all losses, dismantling, restocking fees and any other costs or expenses arising from such termination or suspension. The Seller shall have the right, in addition to any other remedy deemed necessary, to either terminate its agreement to sell the Product(s) or provide the Services or suspend further deliveries of the Product(s) or provision of the Services to the Buyer in the event the Buyer fails to make any payment required to be made to the Seller when due.

10. WARRANTY: Subject to the limitations of liability and remedies set out in Section 12, the Seller warrants its Product(s) and/or Services as follow:

Seller's Products: The Seller will, at its option, repair or replace any defects in material or workmanship in any Product(s) manufactured by the Seller which appear within the earlier of twelve (12) months from the date of initial installation of the Seller's Product(s) by the Buyer, or eighteen months from the date the Seller's Products(s) were delivered to the Buyer.

Re-Sale Products: The Product(s) manufactured by any third party (including the Seller's principals and their affiliated companies) provided by the Seller to the Buyer as the manufacturer's distributor shall be subject to the manufacturer's standard warranty. The Buyer agrees that the Seller shall have no liability for correcting any defect in the materials and workmanship in any re-sale Product(s) and that the Seller's only obligation is to make a reasonable commercial effort to assist the Buyer in making a warranty claim as against the manufacturer's standard warranty.

Services: Any Services supplied by the Seller, including component integration, device configuration, and the repair of Product(s) are warranted against defects in workmanship for a period of the earlier of ninety (90) days from the date of the installation of the Product(s) or one hundred and twenty (120) days from the date of the delivery of the Product(s) to the Buyer. Any interpretative services provided by the Seller are not warranted wither as to the accuracy or correctness of any such interpretations or any recommendations made by the Seller based upon these interpretations.

On-Site Warranty Support: If the Buyer requires the Seller to provide any Services relating to any defect in the Product(s) and/or Services rendered or any warranty claim made by the Buyer in respect of the Product(s) and/or Services, including diagnosis, dismantling, and reinstallation of Product(s), at the Buyer's site, all costs of travel to and from the Buyer's site and of these Services shall be paid by the Buyer at the rates set out in the Seller's published rate schedule in effect at the time the Services are actually provided.



11. WARRANTY EXCLUSIONS:

- a) The Seller does not warrant the performance of any Product(s) and/or services provided by it to the extent that the actual operating or other conditions differ from the specifications or other data supplied by the Buyer for the purpose of selection of design of the Product(s) and/or Services to be provided by the Seller.
- b) This limited warranty shall not apply to any repair or replacement of Product(s) caused by abuse, accidental damage, misuse, improper installation, and improper application, corrosion or inadequate or improper preventative maintenance of the Product(s).
- c) Except as expressly provided herein, there are no other representations or warranties of any kind, express or implied, as to the merchantability, fitness for particular purpose, or any other matter with respect to the product (s) or services.

12. LIMITATION OF REMEDY AND LIABILITY: The Seller shall not be liable for any kind of consequential damages including loss of anticipated profits, loss of use of equipment or any associated equipment, the loss of product from the Buyer's facility(s) or the loss of capital however caused. The Buyer agrees that the Seller's sole and exclusive liability for all losses and damages arising out of or connected in any way with the Product(s) and/or Services provided by the Seller shall be limited to the repair, correction, or replacement of the Product(s) and/or Services in accordance with the terms of limited warranty set out in Section 10 herein. The Buyer further agrees that the Seller's total liability arising out of or connected in any way with the provision of the Product(s) and/or Services is limited to the value of the Product(s) and/or Services provided by the Seller under this Agreement.

13. INDEMNITY: The Seller agrees to protect, defend, and indemnify the Buyer, its respective officers, directors, employees, and consultants from and against any and all claims, demands, losses, causes of action, liability and costs (including all legal costs and attorney fees) of every kind and nature arising out of or connected in any way with damage to property, person injury, or death of the Buyer's employees, or third parties alleged to have been caused by any act or omission of the Seller connected with the Product(s) and/or Services provided by the Seller. The Buyer agrees to protect, defend, and indemnify the Seller, its respective officers, directors, employees, and consultants from and against all claims, demands, losses, causes of action, liability and costs (including all legal costs and attorney fees) of every kind and nature arising out of or connected in any way with damage to property, personal injury, or death of the Seller's employees, or third parties alleged to have been caused by any act or omission of the Buyer.

14. INSURANCE: The Buyer shall provide at its expense property damage insurance or "all risk" builder's risk insurance covering all its property on the basis of full replacement cost value without depreciation which will name the Seller and any manufacturer of the Product(s) as additional insureds with a waiver of subrogation against all insured parties thereunder.

15. GENERAL PROVISIONS:

- a) Buyer shall not assign its rights or obligations under this Agreement without Seller's prior written consent.
- b) There are no understandings, agreements, or representations, express or implied, not specified in this Agreement.
- c) No action, regardless of form, arising out of transactions under this Agreement, may be brought by either party more than two (2) years after the cause of action arose.
- d) This Agreement is formed and shall be construed, performed and enforced under the laws of the Province of British Columbia. Any suit, action, or proceeding arising out of or connected in any way with this agreement shall be brought in a Court of the Province of British Columbia which the parties shall have exclusive jurisdiction to hear and resolve such disputes, subject only to the parties agreeing to resolve such disputes through arbitration.

16. CANCELLATION, CHANGES, AND / OR DELAYS: In the event an order is cancelled; a cancellation charge shall be applied. Cancellation fees shall be at the sole discretion of AWC, and based upon on allocated or buy-in material's status and/or labor applied, as well as a reasonable amount to cover overhead and profit.

Changes to the scope of supply as described in the prevailing Purchase Order, after approval of drawings or release to manufacture shall be subject to a change-order charge and subsequent delivery delay. Where possible AWC shall endeavor to accommodate such changes, however AWC cannot be held responsible for Deliverables that may become affected as a result of such change/s, whether a charge is applicable or not.

In the event of a delay outside the control of AWC, and where substantial work or costs have been incurred by AWC, payment terms shall be adjusted to preserve AWC's initially projected cash position.

AWC shall not accept an order which contains a penalty clause for late delivery unless otherwise described in the quoted Bill of Materials. AWC shall not participate with or become partners in a project where a penalty for late/non-compliant delivery would constitute a financial back-charge or discount to the agreed upon order value. AWC will not accept back-charges or claims for late delivery whether directly or indirectly caused by AWC or its suppliers.

17. FORCE MAJEURE: Neither Party shall be liable for delay or failure in the performance of any of its obligations hereunder if such delay or failure is due to causes beyond its reasonable control, including, without limitation, acts of God, fires, earthquakes, strikes and labor disputes, acts of war, terrorism, civil unrest or intervention of any governmental authority ("Force Majeure"); provided, however, that the affected Party promptly notifies the other Party and further provided that the affected Party shall use its commercially reasonable efforts to avoid or remove such causes of non-performance and to mitigate the effect of such occurrence, and shall continue performance with the utmost dispatch whenever such causes are removed. When such circumstances arise, the Parties shall negotiate in good faith any modifications of the terms of this Agreement that may be necessary or appropriate in order to arrive at an equitable solution. Each Party shall bear its own costs and expenses incurred in connection with Force Majeure (including for any efforts to mitigate the effect or impact of the Force Majeure), and neither shall seek recovery of such costs or expenses from the other Party. Throughout any period of Force Majeure, the Party affected shall provide the other Party with regular status updates, including reasonable and non-binding predictions as to when the Force Majeure condition is likely to cease.



APPENDIX B STANDARD EQUIPMENT WARRANTY

1. For the Warranty Period, AWC PROCESS SOLUTIONS LTD. ("**AWC**") warrants that the identified equipment ("**Equipment**") will be free from material defects in fabrication, subject to the terms of this Warranty.
2. For all valid Warranty Claims made by the Client, AWC will repair or replace any defective parts in the Equipment, free of charge, provided that the defective parts or Equipment are returned to AWC at its request. All returns shall be made at the sole cost of the Customer to the address designated by AWC, shipping costs prepaid. Should AWC determine that a Warranty Claim is not covered by this warranty, the client shall pay AWC its customary charges for any repair or replacement made by AWC.
3. The Client shall give AWC immediate written notice of any Equipment defect upon discovery in compliance with the terms of this Warranty. ("**Warranty Claim**"). Any Warranty Claim that is not made immediately upon discovery, or that is not made in compliance with this warranty or that is made after the expiry of the Warranty Period will not be honoured.
4. This warranty excludes Warranty Claims for:
 - a. any Equipment failure caused directly or indirectly by the improper operation or maintenance of the Equipment,
 - b. any Equipment failure caused directly or indirectly by any failure to comply with the Operations Manual, the Maintenance Manual, system design specifications, any directions issued by AWC from time to time or standard industry operating practices,
 - c. any Equipment that has been modified or repaired by the Client or the Client's Contractor unless it has been modified or repaired strictly in compliance with AWC's written instructions as confirmed by photos and videos taken at the time of the modification or repair and sent to AWC promptly,
 - d. Any damage to Equipment caused by any person intentionally or unintentionally other than by AWC, its employees or contractors,
 - e. Any damage to the Equipment caused by a facility fire, accident, or other mishap,
 - f. Any Equipment parts that are designated as ordinary wear and tear items by AWC from time to time, or
 - g. Any Equipment that has been modified by AWC at the request of the Client or its Contractor against the advice of AWC.
5. Any Warranty Claim shall include a clear written description of the Equipment defect, and all useful data to assist in remedying the defect. Upon request by AWC, the Client shall promptly supply copies of the operators log data, maintenance records, names of the operators operating the equipment, specific photos and videos related to the Equipment, and other data requested by AWC from time to time. If Client has not maintained the operator's log and maintenance records in the manner required by the Operations and Maintenance manual or in a manner inconsistent with normal/standard operating procedures, this warranty may, in AWC's discretion, be invalidated by written notice.



6. The Client shall hire competent operators to run and maintain the Equipment and assist AWC with all information and field work related to any Warranty Claim. Upon receipt of a Warranty Claim, AWC will assist the Client's operator remotely (by telephone or other electronic means) with the diagnosis, repair and replacement of defective Equipment or parts or any other resolution of any Warranty Claim. Immediately after completing any warranty claim repair or part or Equipment replacement, the Client shall send photos and videos showing that the work has been completed in compliance with AWC's instructions. If it is determined that a part requires replacement, AWC will immediately send a replacement part to be installed by the Client. If AWC determines in its discretion that extra warranty support is necessary, AWC or its contractor will attend at the site to repair or replace any defective parts or Equipment.
7. Any Warranty Claims will not be honoured if any payments payable to AWC by the Client, its Contractor or relating to the project are past-due unless payment is promptly made after receipt of written notice from AWC.
8. AWC's sole and exclusive liability to the Client, for the supplied Equipment or services, shall be limited to AWC's obligations in this Warranty whether the claim is based in contract, tort or on any other legal basis. In no event shall AWC be responsible for any claims related to damages, whether direct, indirect, consequential, incidental, liquidated damages or any other damages related to the Equipment or services supplied by AWC or its contractors. In no event shall AWC's total liability to the Client for all claims arising from the supply of the Equipment and services exceed the purchase price of the Equipment. If AWC completes any Equipment repair on a goodwill basis, it shall not constitute any admission of liability relating to the Equipment.
9. This warranty provides the sole remedy for all claims based on a failure of or defect in the Equipment or related to any services supplied by AWC. Any implied or express conditions or warranties regarding the Equipment imposed by any applicable Sale of Goods legislation or other legislation are hereby excluded. Any liability of AWC with respect to the Equipment or services supplied will end on the expiry date of the warranty. Only the identified Client may make a claim under this Warranty. The Warranty shall not be transferrable, without the prior written consent of AWC, which shall not be unreasonably withheld. This warranty shall be interpreted in accordance with the laws of British Columbia, Canada and any claims under this warranty or otherwise against AWC shall be resolved exclusively by the courts in Vancouver, British Columbia.



Certified to ISO9001:2015

10 ALDEN RD., MARKHAM, ON. CANADA L3R 2S1
 Phone: (905) 475-1545 Fax: (905) 475-2021
 Website: www.napier-reid.com

TKE Engineering, Inc.

Date: Jun 16, 2022

Attn.: Travis Bradshaw

File: PR-8841

BUDGETARY QUOTATION

Re: San Antonio Water Company, City of Upland WTP, USA

Napier-Reid is pleased to quote the following water treatment system for the above referenced plant. The system will treat surface water and will remove turbidity and suspended solids. The capacity of the system is 1 MGD and the configuration is 2 x 50%.

Scope of Supply

Water Filtration System

A pressure filtration system comprised of two Napier-Reid free standing multimedia pressure filters with associated valves, instruments & Sch. 80 PVC piping. All components (except vessels) will be pre-assembled on an epoxy coated carbon steel skid unless otherwise indicated in this proposal.

Pressure Filters

TWO Freestanding multimedia pressure filters.

Number of filters	2 x 50%
Total flowrate (MGD)	1
Flowrate per filter (MGD)	0.5
Required feed water pressure (PSI)	40-50
Pressure drop across each filter (PSI)	10 (clean), 20 (dirty)
Diameter of filter vessel	114"
Vessel height	60"
Filtering area/filter (ft ²)	71
Filtering rate (gpm/ft ²)	4.9

Backwash rate (gpm/ft ²)	12
Backwash flow rate/filter (gpm)	851
Backwash duration (min)	7-10
Backwash frequency	Every 12-30 hours
Maintenance requirement	Minimal, fully automated system
Required footprint	25' L x 20' W

Note: The filters are designed to be backwashed with filtered water from the filtered water storage tank (by others). Supply of pressurized filtered water for backwash is by others.

Each filter is complete with:

- 1 - 114" dia. x 60" free standing epoxy coated carbon steel vessel, designed for working pressure of 50 PSI and design pressure of 75 PSI, non-ASME certified.
- 1 - Inlet water distribution system, 316SS header & laterals.
- 1 - Effluent bottom underdrain system, 316SS header & PVC slotted laterals.
- 5 - Electrically actuated on/off butterfly valves on filter inlet, outlet, backwash in, backwash out and rinse.
- 1- Air relief valve.
- 1 - Lot of manual isolation valves.
- 1 - Lot of filter media consisting of:
 - 450 mm of anthracite.
 - 300 mm of sand.
 - 150 mm of garnet.
 - Support gravel (bottom head).

Media is delivered to site in 0.5 or 1 cubic foot bags with an approximate weight of 100 lbs each. Installation of media will be by others.

Instruments

ONE Lot of instruments and gauges, including:

- 4 - Wika pressure gauges, 2" dial, liquid filled, to be installed on each filter inlet/outlet.

- 2 - Siemens or equal differential pressure transmitters, 4-20mA output, one per filter.
- 2 - ABB or E+H magnetic flowmeters, 4-20mA output, 6" line size, to be installed on inlet of each filter.
- 1 - ABB or E+H magnetic flowmeter, 4-20mA output, 8" line size, to be installed on common backwash inlet line.

Face Piping

ONE Lot of Sch 80 PVC face piping.

Equipment Skids

TWO Epoxy coated carbon steel skids, one per filter. The pressure vessels will be free standing and the face piping, valves and instrumentation will be assembled on the skids.

Control Panel

ONE PLC Control Panel, NEMA 4 enclosure, 120/1/60, c/w:

- Main disconnect switch.
- Primary and secondary fusing.
- Control relays c/w bases.
- Allen-Bradley Micro 850 series PLC /w input and output modules.
- Power supply.
- Wiring terminals.
- Touch-screen operator interface.

ONE Lot of PLC programming.

Control panel will be installed on equipment skid.

All wiring from client's control room/DCS to and from Napier-Reid's control panel is the supply and installation of the contractor.

Shop Drawing

- 2 - Sets of shop drawings and submittal information in English.

Operation & Maintenance Manuals

- 2 - Sets of O & M manuals in English.

Site Visits

Site visits are NOT included. Any visits for technical meetings, installation supervision, start-up, commissioning, performance test and operator training will be extra and will be invoiced separately according to our unit rate as follows.

Standard rate for site service is \$1,200 per man-day plus all travel and local expenses at cost. Rate is based on working 8 hours a day, 6 days a week. Travel time will be charged at \$100 per hour up to \$1,200 per day.

Warranty

Napier-Reid Ltd. warrants all equipment manufactured or supplied by it to be free from defects in design, workmanship and material, and conforming to the specification for a period of 12 months from the day of start-up or 18 months after shipment, whichever occurs first.

Exclusions

Napier-Reid specifically excludes from its scope of supply or responsibility the following:

1. All lifting pumps for raw water.
2. Water storage tank(s).
3. Supply of pressurized backwash water.
4. Effluent distribution system.
5. Disinfections of effluent (UV and/or chlorine dosing).
6. Equipment unloading and storage on site.
7. Equipment installation on site.
8. All site-preparation, layout, earthworks, concreted work, concrete testing, soil testing, geotechnical work and local services (such as building permits, fees, inspection and utility locates).
9. All pads, anchor bolts.
10. Field wiring.

- 11. Interconnecting piping between filters.
- 12. Ladders, stairs, gratings and handrails unless mentioned.
- 13. All consumption of water, electricity and chemicals.
- 14. Field and lab tests of any kind are not included in the above prices.
- 15. Items not specifically mentioned in the quote are not included in the above price.
- 16. Napier-Reid is not responsible for any consequential damages and losses, direct or indirect.

Pricing

Total Lot Price (2 x 50% configuration).....USD \$576,900.00

Price adder for one additional filter (3 x 50% configuration in lieu of 2 x 50%).....USD \$272,000.00

Terms

- Ex-Works, our shops in Canada and USA.
- All prices in USD Funds.
- All sales taxes extra, if applicable.
- Payment should be processed and received net 30 days after submission of valid invoice according to the following progress payment schedule:
 - o 10% upon the receipt of shop drawings by the buyer’s representative.
 - o 35% upon drawing approval.
 - o 50% upon delivery.
 - o 5% upon successful start-up and commissioning.
- Drawings: 4 to 6 weeks from approved purchase order.
- Delivery: 18-22 weeks from approved drawings.
- Purchaser must be approved by our credit department.
- Price validity: 30 days.
- Napier-Reid Ltd. reserves the right to withhold equipment and/or services when payment is not received as per our terms, without penalty, notwithstanding the purchasing contractor’s purchase order, pre-selection or specification documents.
- In the event the purchase order is cancelled, Napier-Reid Ltd. reserves the right to receive reimbursement from the purchaser for all costs incurred up to the date of cancellation including design and restocking charges and a prorated portion of profits.

NAPIER-REID LTD.

A handwritten signature in black ink that reads "Milad Dirani". The signature is written in a cursive style with a small dot above the 'i' in "Dirani".

Milad Dirani (Ext: 221)
Project Manager/Application Engineer
miladdirani@napier-reid.com

Cc: Frank Li, P.Eng. Vice-president

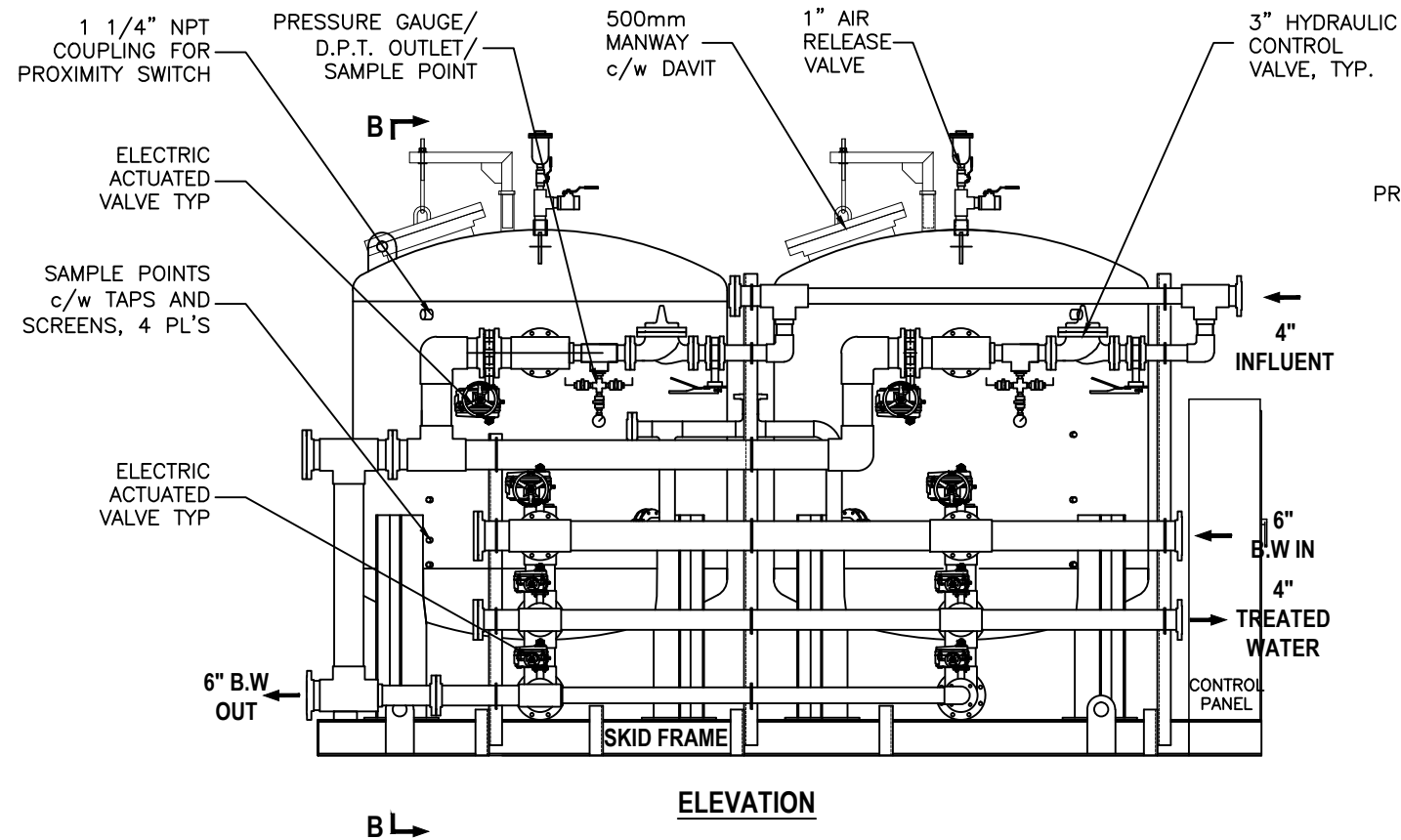

ELEVATION

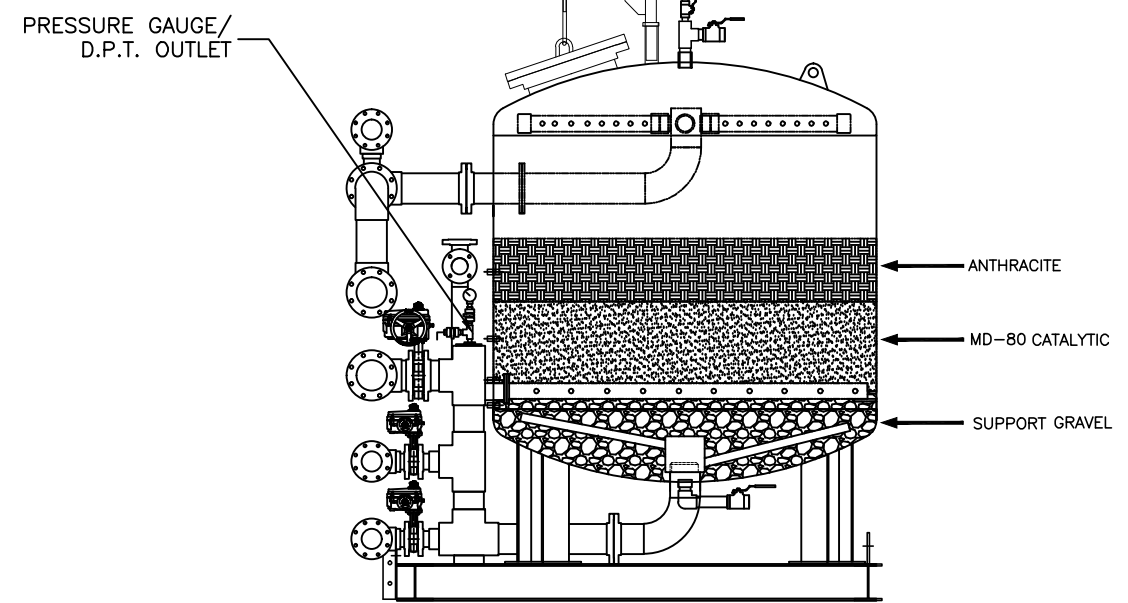

SECTION B-B

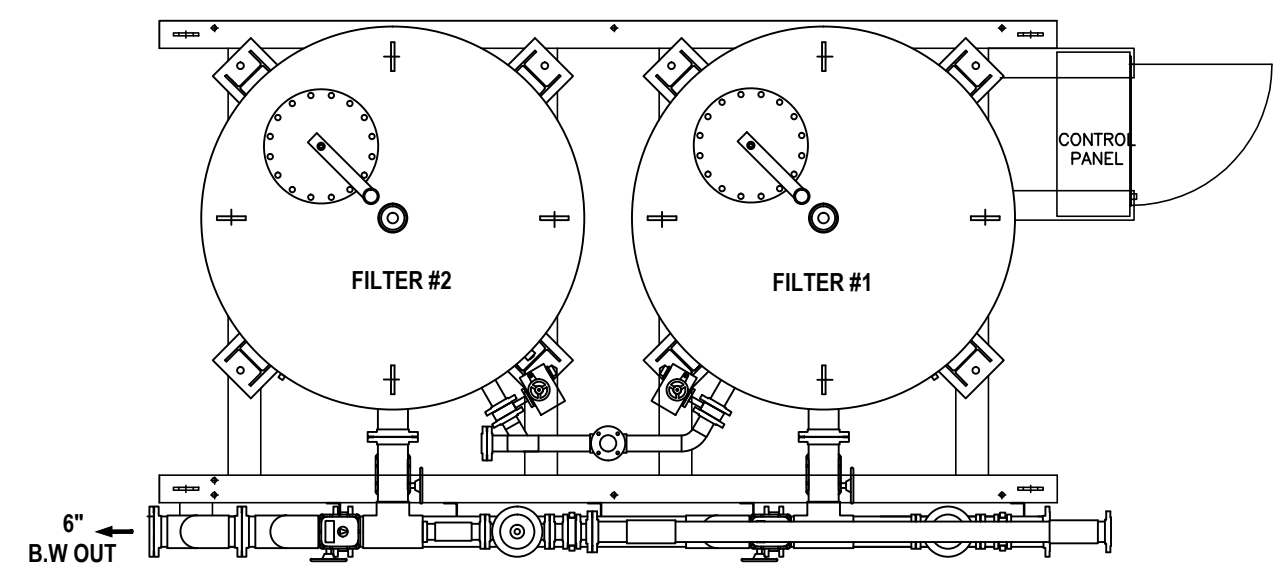

PLAN
(ONLY UPPER LEVEL PIPING SHOWN FOR CLARITY)

REV	DESCRIPTION	DD / MM / YYYY	DESIGN	CHECK	APPR.	NOTES

		REVISION HISTORY	
		SCALE NTS OR AS NOTED	FILE NO.: DWG NO.:
CUSTOMER	PROJECT	DESIGN DATE:	SHEET 01 OF 01
CONTRACTOR	CONSULTING ENGINEER	PLOT DATE:	VERSION R 00



The UVLW is a range of 800W low pressure, high output amalgam UV systems that are validated to the 2003 and 2012 NWRI Reuse Guidelines

Model	Connection (Inches)	# of Lamps (800W)	Dimensions						Panel Dimensions		
			A	B	C	D	E	F	W	H	D
UVLW-6800-10	8	6	105	22	83	75	25	10	32	79	24
UVLW-6800-14	10	6	110	23	87	75	31	12	32	79	24
UVLW-8800-14	10	8	110	23	87	75	31	12	62	79	24
UVLW-16800-20	16	16	121	26	95	75	40	15	62	79	24
UVLW-20800-20	16	20	121	26	95	75	40	15	94	79	24
UVLW-22800-24	20	22	121	27	94	75	47	18	94	79	24
UVLW-30800-24	20	30	121	27	94	75	47	18	94	79	24
UVLW-30800-30	20	30	122	28	94	75	55	21	94	79	24
UVLW-45800-30	20	45	122	28	94	75	55	21	125	79	24

CHAMBER

316L SS
ANSI 150# flanged connections
Install inline, horizontally or vertically
Features:
Access Hatch
Twist lock lamp connections
Dry UV intensity monitor
High purity quartz thimbles
Low voltage automatic wiper
One piece wiper ring
Temperature sensor
Drain and vent ports

CONTROL SYSTEM

NEMA 12 epoxy coated mild steel enclosure
Operational 32-113°F, RH < 90%
Features:
7" HMI
Spectra II control system
MODBUS
Multiple warnings and alarms
Variable power lamps
480V/3-phase

SYSTEM OPTIONS

304 or 316 NEMA 4X enclosures
Effluent flange location
Skid mounted
Containerized
Internal/external polish or electropolish

INSTALLATION NOTES

Provide necessary maintenance space
Install in a dry area
Provide floor drain or sump
Lamps submerged at all times
Minimum of two conduits required
Chamber must be grounded

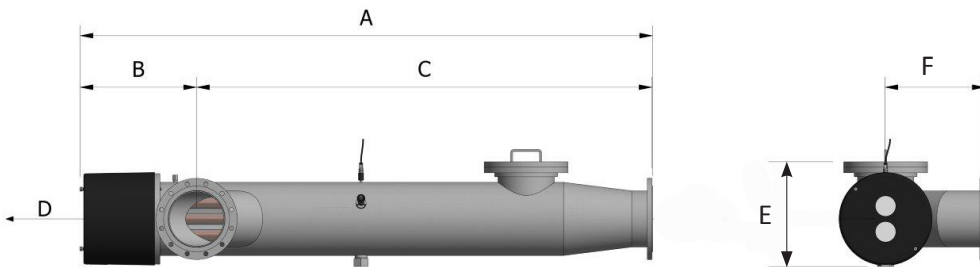

We UVCare...

Application Optimized UV for Drinking Water



PROLINE PQ IL



Validated UV treatment
for drinking water

Our ProLine PQ IL systems are aimed specifically at providing USEPA third party validated UV disinfection for municipal drinking water. By using a USEPA third party validated UV system, you can be assured that the UV dose being produced will disinfect the water from harmful micro-organisms and lower operating costs. Each system comes with one certified dry UV sensor per lamp, allowing checking of UV performance. The UV sensor measures the germicidal output of the UV system and a UV dose read out makes it easy to monitor and log performance. The control system also has the ability to take flow and transmittance meter inputs and calculate the UV dose based on real time operating conditions.

berson

hanovia

aquionics

Potential location of the ProLine PQ IL™ in drinking water treatment process

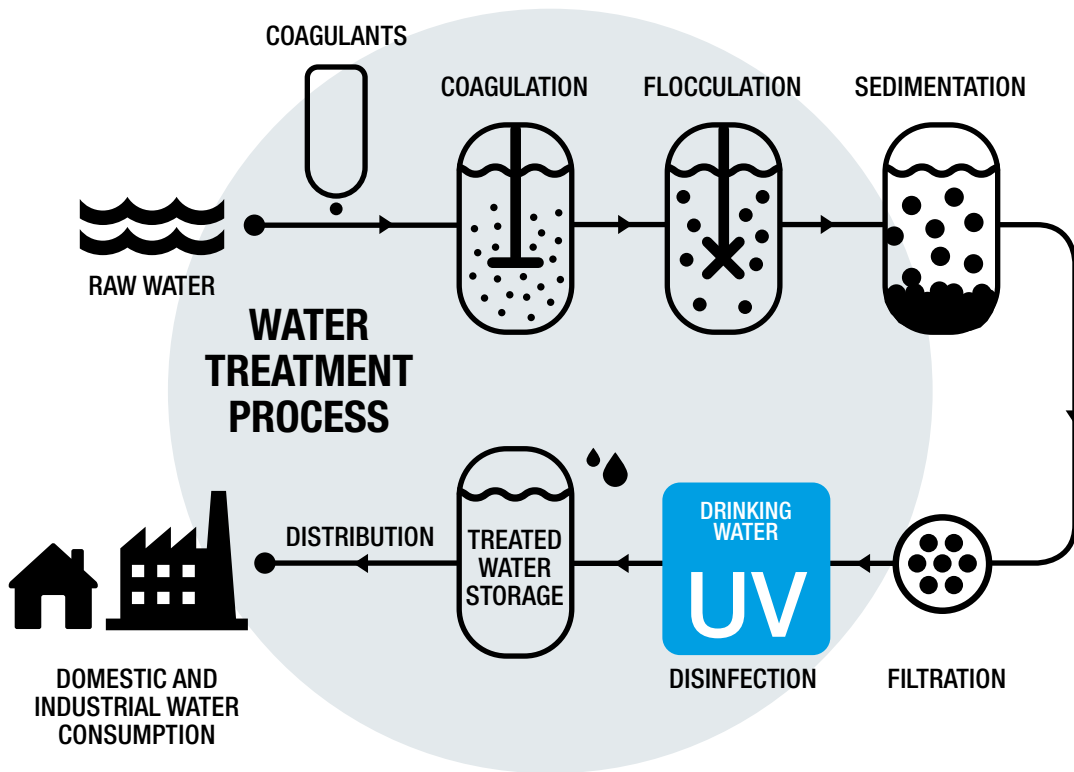

KEY FEATURES	WHAT IT GIVES YOU	BENEFITS FOR YOU
INTELLIGENCE		
Dry DVGW approved UV sensor measuring germicidal wavelengths	Continuous verification of performance with real time RED dose reading and in-built low dose warning	Easy to monitor and log system performance
Flow and UV transmittance (UVT) meter inputs	Dose reading based on actual process conditions when meters are connected	Accurate UV dose reading guaranteed under wide range of operating conditions
OPTIMIZATION		
Third party validated UV systems tested in accordance with the USEPA UV Disinfection Guidance Manual	UV system dose equations and sizing have been independently derived	Confidence the system will perform as stated
UV water disinfection	Protects your drinking water from microbiological contamination including chlorine resistant <i>Cryptosporidium</i> and <i>Giardia</i>	Does not affect taste and odour No chemicals
Designed for the treatment of drinking water	NSF-61 approved materials used for all wetted parts	Industry compliant materials
	Flanged connections, high standard internal finish	Designed to international standards
	Automatic wiper (quartz cleaning)	Self cleaning to maintain performance
INTEGRATION		
Compact design	Can be retrofitted to existing process	Easy integration

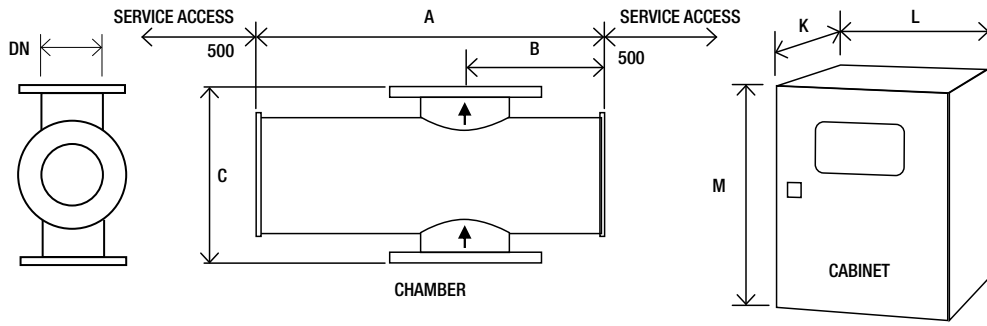

* Allow dimension L in front of cabinet for door opening and panel access.
 ** M dimension includes the space for the cabinet mounting brackets but you need to allow space below the cabinet for cable entry and access (minimum of 9.8").
 *** CC: Control cabinet, PC: Power cabinet
 ▫ Attention: the optional cabinet with A/C is bigger. Ask for dimensions.
 All dimensions are approximate for clearance purposes only. We have a policy of continuous product development, exact drawings are available on request. All specifications are subject to change without notification. Your distributor or our account manager can advise on correct sizing and specification requirements.

Model Number	Max. power (kW)	No of lamps	Dimensions (Inches)					DN	Approx weight (lb)			
			Chamber		Cab. No***	Cabinet (fan cooled) ^a	M**		Chamber Empty	Cabinet Fan cooled		
			A	B				C			K*	L
ProLine PQ IL 450	5.6	2	30.7	12.2	15.7	8	1	11.8	39.4	47.2	172	176
ProLine PQ IL 1000	11	4	30.7	12.2	15.7	8	1	11.8	39.4	47.2	172	220
ProLine PQ IL 4000	17.5	4	35.3	14.5	21.7	14	1	23.6	39.4	82.7	331	397
ProLine PQ IL 4500	26	6	35.3	14.5	21.7	14	1	23.6	39.4	82.7	331	441
ProLine PQ IL 12000	39	6	41.4	17.6	26.8	20	1 CC	15.7	23.6	78.7	529	287
							1 PC	23.6	47.2	82.7	573	
ProLine PQ IL 14000	52	8	41.4	17.6	26.8	20	1 CC	15.7	23.6	78.7	529	287
							1 PC	23.6	47.2	82.7	639	

UV CHAMBER	
Material:	StSt 316L / 1.4404
Internal finish:	< 0.8 µm Ra, welds ground out, electropolished and passivated
External finish:	Brushed to K280, electropolished and passivated
Process (mating) connections:	ANSI 150#
Drain connection:	BSP or NPT if ANSI flange
Air vent connection:	BSP or NPT if ANSI flange
End plate:	Removable end plate
Degree of protection:	IP54 equivalent to NEMA 12
Wiper:	Automatic (electrically driven)
UV lamp:	Medium pressure
Quartz sleeve:	Doped quartz (F240)
Number of UV lamps:	See table above
Expected lamp life:	12,000 hours
Temperature sensor:	Yes
UV sensor:	Dry DVGW compliant UV sensor (one per lamp)
Working fluid temperature:	33.8°F to 140°F
Hydrostatically pressure tested:	Yes
Chamber mounting:	Flow horizontal or vertical (lamps horizontal only)
Operating pressure:	10 bar (positive pressure only)
Seals:	EPDM, ADI free, EC 1935/2004, FDA 21 CFR 177.2600 approved

OPTIONS	
Document Support Pack	
Cabinet material: Stainless steel 304	
Cabinet material: Stainless steel 304 with air conditioning (41-122°F), IP66 (NEMA 4x), relative humidity <95% non condensing*	
Cabinet material: Stainless steel 316 with air conditioning slooping roof (41-122°F), IP66 (NEMA 4x), relative humidity <95% non condensing*	
Operation and Maintenance manual and printed Installation and Commissioning manual in Chinese, English, French, German & Spanish	
Flange options: PN16, ANSI 150, JIS, Table 'E'	
Lead length: 65.6 ft and 95.1 ft	
In-field UV reference sensor kit	
Bleed: valve with BSP connection or NPT if ANSI flange	
Water leak detection: Detects water leaks from quartz sleeve	
Water level sensor: UV chamber full water detection	

* See sales drawings for dimensions

OPTIONS (CONTINUED)	
UL 508 A shop approval	
Operating pressure: Higher pressure available upon request (Brian: 10 bar)	
Allen Bradley AB850 & UV Touch HMI (Brian: UVtronic)	

CABINET (CONTROLLER UVTRONIC)	
Material:	Polyester coated carbon steel, RAL 7035
Degree of protection:	IP54 (NEMA 12)
Supply voltages:	PQ IL 450-1000: 200-277 V (+/- 10%) (2ph L1,L2 or 1ph L1+N) PQ IL 4000-14000: 380-480 V (-5 to +10%) (3ph L1, L2, L3) 50/60 Hz
Operating temperature range:	41°F to 95°F
Relative humidity:	<85% non-condensing
Cooling fans:	Yes
Interconnecting cable:	32.8 ft
Variable power:	Variable power (70% reduction from maximum ballast power)

HMI / CONTROL	
Display:	4 line LCD, indicating system status including alarms
Operating menu:	3 levels (2 with password protection)
Fault finding:	Event log

CUSTOMER OUTPUTS	
4-20 mA passive output:	UV dose, UV intensity, ballast power
VFC outputs:	Standby in remote, system standby, system cooling down, any trip, any warning, UV dose failure, system ready, wiper failure, lamp failure, water leak, water temperature warning, Full water detection, water & cabinet temperature alarm

CUSTOMER INPUTS	
4-20 mA active or passive inputs:	Flow meter and UVT transmittance meter inputs:
VFC inputs:	Remote stop/start, remote clear message, remote wipe, remote set power high

CUSTOMER COMMUNICATIONS PORT	
Modbus RS 485 serial RTU for SCADA connection	

APPROVALS	
CE marked, USEPA (UVDGM), NSF 61	



PROLINE PQ IL

Also available in our Drinking Water product range...



PROLINE PQ AF

Small community, low energy amalgam range with USEPA validation.



PROLINE PQ AL

Small to mid-sized community, low energy multi-lamp amalgam range with USEPA validation and built in UVT compensation



PROLINE PQ EO

Energy Optimized medium pressure range, USEPA validated with built in UVT compensation



PROLINE PQ IL DVGW

Compact medium pressure range with DVGW certification, for use where space is tight in small to mid-sized communities



www.weuvcare.com

BERSON, HANOVIA & AQUIONICS WORKING TOGETHER AS PART OF THE HALMA GROUP.

Netherlands

t: +31 40 2907777
e: sales@bersonuv.com

China

t: +86 21 61679599
e: china@hanovia.com

USA

t: +1 980 256 5700
e: sales@aquionics.com

Germany

t: +49 800 5892779
e: verkauf@hanovia.com

Malaysia

t: +60 16 440 8834
e: asia@hanovia.com

Canada

t: +1 980.256.5700
e: sales@aquionics.com

United Kingdom

t: +44 1753 515300
e: sales@hanovia.com

Mexico

t: +1 980.256.5700
e: sales@aquionics.com



A **Halma** company



WASTEWATER DISINFECTION



Revolutionary Advancement in Wastewater Disinfection

Ideal for mid- to large-scale primary, secondary, and reuse applications

UV is the most effective, safe and environmentally friendly way to disinfect wastewater. It provides broad-spectrum protection against a wide range of pathogens, including bacteria, viruses and chlorine-resistant protozoa such as *Cryptosporidium* and *Giardia*.

Chlorine is not the only viable disinfection option for mid- and large-scale applications. With the TrojanUVSigna™, operators and engineers can confidently choose UV and benefit from its inherent safety features, cost-saving advantages and disinfection performance.

TrojanUVSigna incorporates innovations, including TrojanUV Solo Lamp™ Technology, to reduce the total cost of ownership and drastically simplify operation and maintenance. It is the ideal solution for treatment plants in need of revolutionary UV technology.

Key Benefits

TrojanUVSigna

Low lamp count and high electrical efficiency. The revolutionary, 1000 Watt TrojanUV Solo Lamp combines the best features of low- and medium-pressure lamps.

Modular and compact. UV banks are available in two-row, four-row and six-row lamp configurations, thus accommodating various channel depths.

Optimized power consumption. Banks are turned on/off based on UV demand. The advanced Solo Lamp Driver enables lamp dimming from 100 to 30% power and has built-in diagnostic capabilities for easy troubleshooting.

Simple water level control. Light locks at each bank enable high tolerance to fluctuations in flow rates and water levels, simplifying water level control while maximizing disinfection.

Less time spent changing lamps. Fewer lamps, long lamp life and easy change-outs save time and money.

Chemical and mechanical sleeve cleaning. Without removing equipment or disrupting disinfection, the dual-action ActiClean™ system provides superior, automatic lamp sleeve cleaning.

Worry-free maintenance. Lamp change-outs and cleaning solution replacement are done while the UV bank is in the channel.

Easy bank removal. Routine maintenance can be performed while banks are in the channel, but an Automatic Raising Mechanism (ARM) makes other tasks – such as winterization – simple, safe and easy.

Simple retrofitting. Stringent tolerances on concrete channel walls are not required, making chlorine contact tank and UV channel retrofits simple and cost-effective. Retrofits can accommodate existing water level profile and head loss.

TROJAN UV SIGNA™

Compact, modular wastewater disinfection



Power Distribution Center (PDC)

The compact PDC panel contains state-of-the-art lamp drivers that power and control the UV lamps. Lamp drivers are rack-mounted in a compact outdoor-rated panel, are quick and easy to change, and generate very little waste heat. Multiple PDCs are available when required.

Lamp LED Indicator

Lamp plugs with LED status indicators and integral safety interlock prevent an operator from accidentally removing an energized lamp. In addition to the System Control Center (SCC), lamp status is shown locally and visually with the LED.

ActiClean Sleeve Cleaning System

Dual-action cleaning system uses mechanical wiping in conjunction with a cleaning solution contained within wiper canisters surrounding the quartz sleeves. This advanced system operates automatically, without operator involvement, reducing maintenance and ensuring maximum UV output every day. Quartz sleeves and intensity sensors are cleaned regularly without disrupting disinfection.

Shown here is the two-row lamp configuration.

Modular UV Bank (available in two-row, four-row or six-row lamp configurations)

A bank consists of TrojanUV Solo Lamps, positioned in a staggered, inclined array. With a push of a button, the ARM lifts the bank out of the channel. Integral bank walls optimize performance, prevent short-circuiting and simplify installation by eliminating the need for stringent concrete tolerances at the walls.

Banks are also available in four- and six-row lamp configurations, with concrete culvert. Shown here (in the image to the right) is the four-row.



Light Locks

Regardless of flow rate, high or low, light locks help direct the flow through the bank, maximizing disinfection and efficiency while minimizing quartz sleeve fouling.



TrojanUV Solo Lamp Technology

The revolutionary TrojanUV Solo Lamp enables high electrical efficiency and reduced lamp count. Lamps are located within protective quartz sleeves and positioned in a staggered, inclined array for maximum disinfection performance and easy accessibility.

Revolutionary Lamp and Driver Technology

The best features of both low- and medium-pressure lamps



Benefits:

- Energy-efficient, 1000 Watt TrojanUV Solo Lamp
- High UV output, high electrical efficiency and lowest total lamp count
- Power consumption is approximately 1/3 that of medium-pressure lamps
- Long lamp life (15,000 hours guaranteed)
- Solo Lamp Driver has a high power factor, low total harmonic distortion, and cost-saving lamp dimming from 100 to 30% power
- Solo Lamp Drivers are rack-mounted for easy removal and replacement, if required

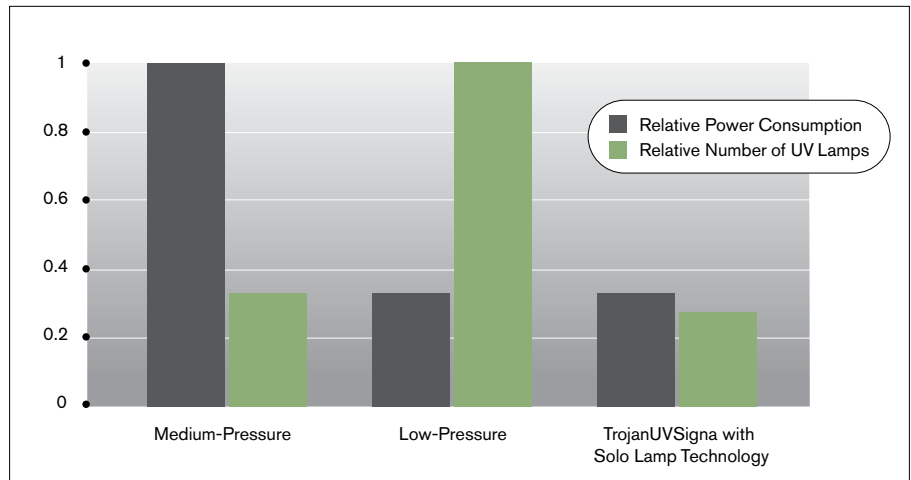

TrojanUV Solo Lamp systems combine the benefits of other lamp technologies – the low lamp count of medium-pressure systems with the high electrical efficiency of low-pressure high-output (LPHO) systems. The result is a compact, cost-effective installation that is easy and quick to maintain.

Bioassay Validation

Ensures accurate dose delivery

Benefits:

- Real-world performance data is generated over a range of flow rates, UVT, and using multiple organisms to represent pathogens with varying UV resistance
- Bioassay validation is the only way to evaluate disinfection performance of a UV system
- Incorporates the impact of actual lamp output, lamp spacing and configuration, hydraulics, quartz sleeve transmission, lamp driver efficiency and other variables affecting performance
- Third-party validations to USEPA UVDGM, NWRI and IUVA for secondary and high-level reuse applications



Validation testing incorporates UV sensors for accurate dose delivery and disinfection confidence.

Easy Operation and Simplified Maintenance

Designed to make the operator's job easier

Benefits:

- Reduced number of lamps means less time and money spent changing, maintaining and replacing them
- Dose pacing extends lamp life and reduces number of lamps replaced each year
- Safety interlocks prevent operators from accidentally removing an energized lamp
- The dual-action ActiClean system provides superior, automatic sleeve cleaning to remove fouling
- Cleaning solution can be refilled anytime, without removing banks from the channel



Routine maintenance is performed while banks are in the channel. However, when needed, banks can be raised by pressing a button and activating the ARM.

Proven Disinfection Performance

Revolutionary UV technology and design features guarantee optimal results

Benefits:

- Light locks direct the flow through the bank, enabling high tolerance to water level changes and maximizing the UV energy delivered to the effluent
- Integral bank walls eliminate the risk of short-circuiting
- Staggered, inclined array – optimized through computational fluid dynamics – reduces sleeve stress and debris collection, and maximizes disinfection performance
- Advanced, NIST-traceable sensors continuously monitor lamp intensity to guarantee disinfection and meet permit requirements while balancing energy usage

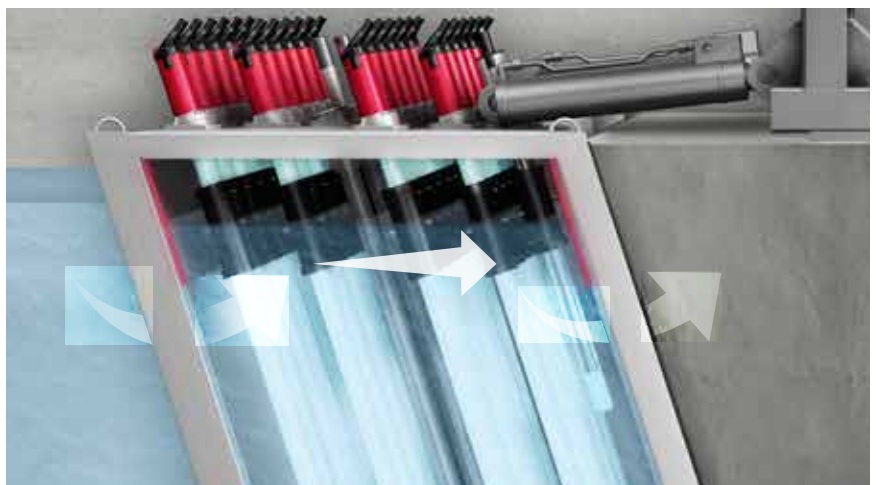

Light locks, along with downstream level controller, ensure that no portion of the lamp arc is exposed to air. This ensures operator safety, prevents sleeve fouling and maximizes disinfection.

Flexible Installation and Easy Retrofitting

Cost-effective installation in existing effluent channels

Benefits:

- Designed to fit into an existing chlorine contact chamber, thus reducing civil and concrete work
- Integral bank walls and light locks make retrofits or new installations easy; disinfection performance no longer relies on concrete channel wall tolerances or downstream water level controller
- All system components can be installed outdoors
- Modular design reduces channel depth and length requirements



The TrojanUVSigna can be installed in an existing chlorine contact tank without major modifications to the channel depth or width. Gone are the days of time-consuming installations requiring new concrete walls with tight tolerances or stepped floors. Shown here is the four-row lamp configuration.

System Specifications

System Characteristics	TrojanUVSigna
Lamp Type	TrojanUV Solo Lamp (amalgam)
Lamp Driver	Electronic, high-efficiency (99% power factor)
Input Power Per Lamp	1000 Watts
Lamp Control	30 - 100% variable lamp power (1% increments)
Lamp Configuration	Staggered, inclined array (two-row, four-row or six-row)
Module/Bank Frame	Type 6P (IP68)
Ballast Enclosure	Type 4X (IP56)
Cleaning System	Automatic ActiClean chemical/mechanical
UV Intensity Sensor	1 per bank – with automatic chemical cleaning
Bank Lifting Device	1 per bank - Automatic Raising Mechanism (ARM)
Level Control Device	Fixed weir or motorized weir gate
Water Level Sensor	High and low water level sensors available (one per channel)
Installation Location	Indoors or outdoors
System Control Center	Standard color HMI, 16 digital I/O, 4 analog I/O, SCADA compatible PLC options available

TrojanUV is part of the Trojan Technologies group of businesses.

Head Office (Canada)

3020 Gore Road London, Ontario, Canada N5V 4T7
Telephone: (519) 457-3400 Fax: (519) 457-3030

www.trojanuv.com

For a list of our global offices, please visit trojanuv.com/contactus.

Trojan Technologies Deutschland GmbH

Aschaffburger Str. 72, 63825 Schöllkrippen, Germany
Telephone: +49 (0) 6024 6347580 Fax: +49 (0) 6024 6347588

The products described in this publication may be protected by one or more patents in The United States of America, Canada and/or other countries. For a list of patents owned by Trojan Technologies, go to www.trojanantechologies.com.

Copyright 2015, Trojan Technologies London, Ontario, Canada.
No part of this publication may be reproduced, stored in a retrieval system, or transmitted in any form or by any means without the written permission of Trojan Technologies. (0415)